

PROJECT VRF R410A FULL DC INVERTER

EEV KIT

Kit for connecting AHU with direct expansion battery to Hokkaido XRV systems.



HAHU 9-20 XRV-K
HAHU 20-36 XRV-K
HAHU 36-56 XRV-K

EEV-KIT lets you connect direct air handling unit expansion coils to XRV systems.

These kits are composed of an expansion valve and electronic control to manage refrigerant flow toward the AHU: in this way, AHU systems can make use of the advantages linked to XRV technology.

EEV-KIT Application diagrams

Diagram type A: Mixed system indoor unit XRV + AHU

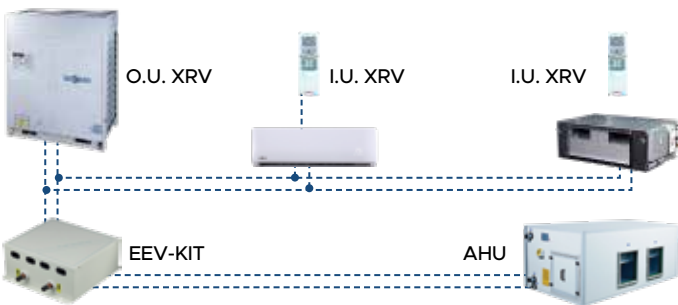
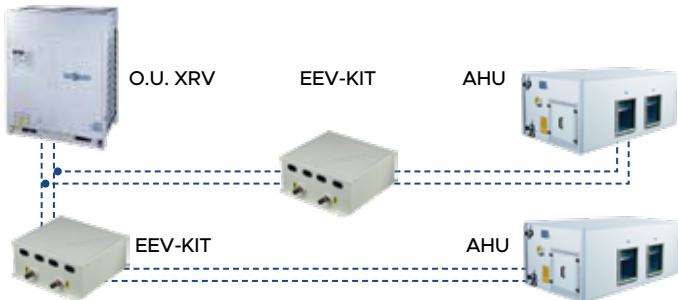
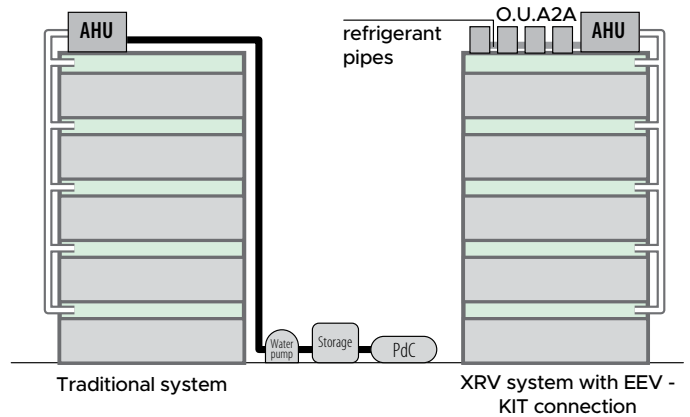

Diagram type B: AHU only



Traditional VS XRV systems with EEV-KIT

Below is a comparison between a traditional connection system and an XRV system with EEV-KIT connection.



EEV-KIT Advantages

High energy efficiency thanks to XRV technology which involves:

- improved indoor temperature control in rooms
- reduced energy consumption linked to Inverter technology
- reduced outdoor unit start&stop cycles
- lower installation and maintenance costs with respect to traditional systems which use an AHU

Installation and operation

Here are a series of instructions regarding EEV-KIT functionality and the correct installation methods.

- Failure feedback function: error codes can be shown on the display when malfunctions occur. It is also possible to verify the set temperature.
- Maximum Number of EEV-Kit that can be connected to an AHU: 4 (maximum reachable capacity 224 kW).
- Maximum distance between EEV Kits and AHU: 8 m. Kit can be connected with XRV systems with R410A refrigerant gas, except for heat recovery systems (XRV 3 pipes).

PROJECT VRF R410A FULL DC INVERTER

EEV KIT

Technical data

Model	HAHU 9-20 XRV-K	HAHU 20-36 XRV-K	HAHU 36-56 XRV-K
Rated heating (kW)	9~20	20.1~36	36.1~56
Power supply (Ph-V-Hz)	1-220~240V-50Hz		
H x L x P (mm)	375 x 350 x 150		
Net weight (kg)	8.4	8.7	8.9
In/out refrigerant connections [Ø mm (inch)]	7.9 (5/16")	12.7 (1/2")	15.9 (5/8")
Serial control (type)	Wired remote control		
Optional parts			
Third-party control	Siemens POL 638.70		
Centralised control	See compatibility table		

Electrical connections diagram

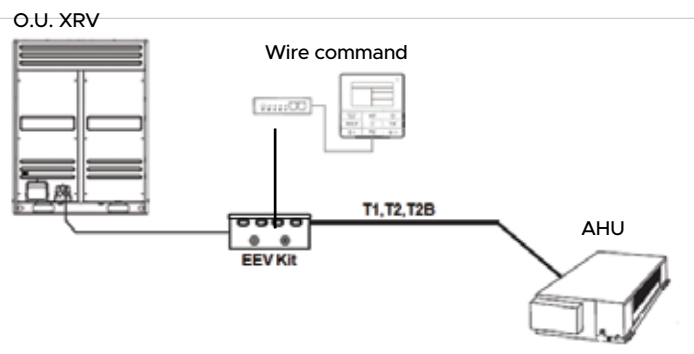

Room temperature control occurs with the same logic as an XRV: comparing the temperature detected by the T1 sensor and the setting temperature Ts, it is possible to start or stop the outdoor unit, calculate the required thermal load and manage the refrigerant flow through the electronic expansion valve.

EEV-KIT type selection

Model	HP	I.U. rated capacity (kW)
HAHU 9-20 XRV-K	3.2	Between 9.0 and 11.2 kW
	4	Between 11.2 and 14.0 kW
	5	Between 14.0 and 18.0 kW
	6	Between 18.0 and 20.0 kW
HAHU 20-36 XRV-K	8	Between 20.0 and 25.0 kW
	10	Between 25.0 and 30.0 kW
	12	Between 30.0 and 36.0 kW
HAHU 36-56 XRV-K	14	Between 36.0 and 40.0 kW
	16	Between 40.0 and 45.0 kW
	18	Between 45.0 and 50.0 kW
	20	Between 50.0 and 56.0 kW

Master-slave connection logic

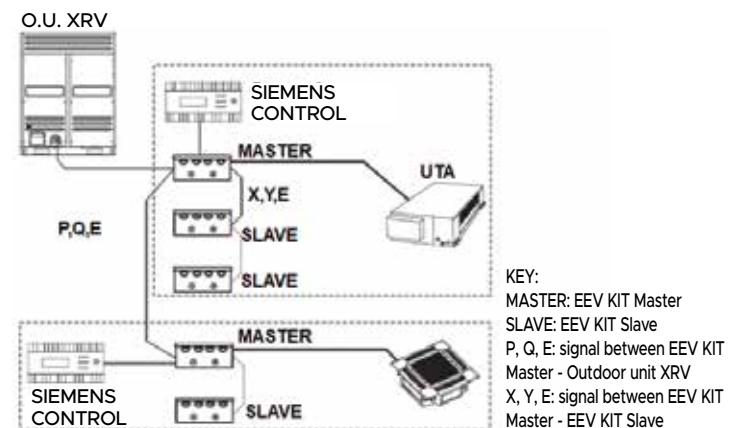

In the case of parallel connections of more than one EEV-KIT to service a AHU, the connection logic to be followed is that of Master-Slave.

The choice of the quantities and capacity of the EEV KITS to be installed is related to the power of the AHU to which it must be connected.

Example

If the AHU has a capacity of 92 kW, 2 EEV-KITs can be installed:

HAHU 36-56 XRV-K - setting capacity 20HP

HAHU 20-36 XRV-K - setting capacity 12HP