

PROJECT VRF R410A FULL DC INVERTER

XRV PLUS MINI Heat pump



FULL DC INVERTER
HCNU 1054 XRV-1 Plus



FULL DC INVERTER
HCSU 1404 XRV-1 Plus
HCSU 1604 XRV-1 Plus
HCSU 1804 XRV-1 Plus

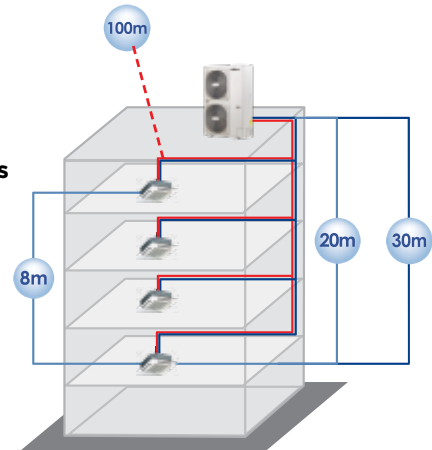

Splitting lengths and height differences

Maximum length of the pipes = 100 m

All units are equipped with a high efficiency Full DC Inverter compressor.

Slim, flexible design.

DC Inverter motor fan:

- wider fan speed adjustment range
- reduced noise level

Optimal design of the fan and fan-shaped louvre, that ensure low noise level at high air flow.

Broad operating range

- cooling -15° C ~ +43° C;
- heating -15° C ~ +27° C;

Auto-addressing of indoor units.

Maximum distance between O.U. and the farthest I.U. = 70 m (50 m for HCNU 1054 XRV-1 Plus)

Maximum distance from the first branch pipe to the farthest = 20 m

Maximum height difference between O.U. (up high) and I.U. = 30 m

Maximum height difference between O.U. (down low) and I.U. = 20 m

Maximum height difference between I.U. = 8 m

Maximum length of the pipes = 100 m

Model			HCNU 1054 XRV-1 Plus	HCSU 1404 XRV-1 Plus	HCSU 1604 XRV-1 Plus	HCSU 1804 XRV-1 Plus
Power	HP		3.75	5	6	6.5
Rated cooling capacity (1)	kW		9	14	15.5	17.5
Rated heating capacity (2)	kW		9	15.4	17	19
Electrical data						
Power supply	Ph-V-Hz		1-220~240V-50Hz		3-380~415V-50Hz	
Electric consumption in cooling mode (rated)	kW / A		2.30 / 10.4	3.95 / 9.3	4.52 / 10.7	5.30 / 12.5
Electric consumption in heating mode (rated)	kW / A		2.27 / 10.3	4.15 / 9.8	4.77 / 11.3	5.00 / 11.8
EER performance coefficient in cooling mode	W/W		3.91	3.54	3.43	3.3
COP performance coefficient in heating mode	W/W		3.97	3.71	3.56	3.8
Refrigerant circuit/features						
Refrigerant	type (GWP)		R410A (2088)			
	Kg (tons CO2)		2.95 (6.160)		3.9 (8.143)	4.5 (9.396)
DC Inverter compressor	no. / type		Rotary DC inverter MITSUBISHI			
Refrigerant connections	Liquid	Ø mm (inch)	9.53 (3/8")		9.53 (3/8")	
	Gas	Ø mm (inch)	15.9 (5/8")		19.1 (3/4")	
Max pipe length	m		100			
Max height difference between indoor units	m		8			
Max height difference between outdoor and indoor units	O.U. up-down	m	30 - 20			
Product specifications						
Dimensions	LxHxD	mm	990(+85)x966x354		900x1327x348	
Net weight		Kg	75.5	95	102	107
Sound pressure level at 1 m	max	dB(A)	54		57	59
Sound power level	max	dB(A)	68	73	73	74
Fan air flow	max	m ³ /h	5500		6000	6800
Operating temp. range in cooling mode		°C / DB	-15 / 43			
Operating temp. range in heating mode		°C / WB	-15 / 27			
Connectable indoor units	no.		5	6	7	9
Capacity of connected indoor unit	%		45 - 130			

(1) Cooling capacity tested in accordance with ISO 5151 Standards; outdoor temperature 35° C DB, 24° C WB and indoor temperature 27° C DB, 19° C WB.

(2) Heating capacity tested in accordance with ISO 5151 Standards; outdoor temperature 7° C DB, 6° C WB and indoor temperature 20° C DB, 15° C WB.