

XRV MULTI SYSTEM - FULL DC INVERTER

XRV PLUS HEAT RECOVERY

Heat recovery - 3 pipes



HCSRU 2524 XRV-1 Plus
HCSRU 2804 XRV-1 Plus
HCSRU 3354 XRV-1 Plus
HCSRU 4004 XRV-1 Plus
HCSRU 4504 XRV-1 Plus

The range is characterised by 5 basic modules: 8, 10, 12, 14 and 16HP. All outdoor unit compressors are Full DC Inverter type for a high level of efficiency.

Possibility of connecting up to 24 indoor units with only one flow divider.

The indoor units can operate in different modes even if they are connected to the same flow divider.

Wide range in operating conditions: from -20°C WB in heating mode up to $+43^{\circ}\text{C}$ DB in cooling mode with no stop.

High splitting distance: max distance between I.U. up to 200 m, total length up to 1000 m.

HIGH ENERGY EFFICIENCY

Fan and grille.



Integrated electric circuit.



Control of DC Inverter wave at 180° (IPM).



DC Inverter fan, low noise level, low consumption, high efficiency.

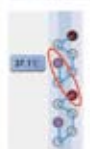

Highly efficient heat exchanger.

High pressure DC Inverter Scroll compressor contributes to very high efficiency.



SPLITTING LENGTHS AND HEIGHT DIFFERENCES

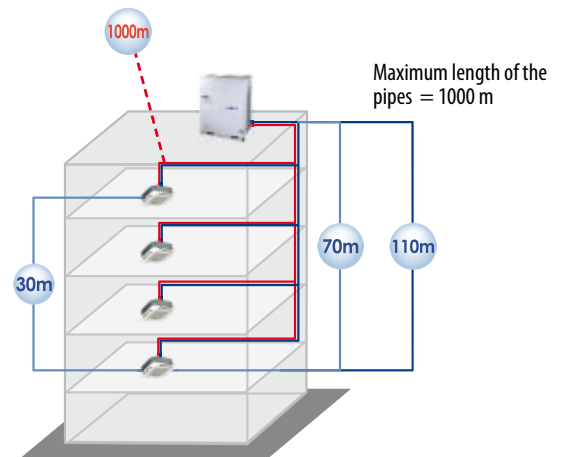

Max distance between OU and the farthest IU = 200 m
Max distance from the divider to the farthest IU = 40 m
Max distance from the first branch pipe to the farthest IU = 90 m
Max height difference between OU (up high) and IU = 70 m
Max height difference between OU (down low) and IU = 110 m
Max height difference between IU = 30 m
Maximum length of the pipes = 1000 m

HEATING DURING DEFROST

XRV Plus heat recovery remarkably reduces defrost time thanks to the particular structure of the heat exchanger, therefore with non-stop operation.

Curve of heating capacity during defrost

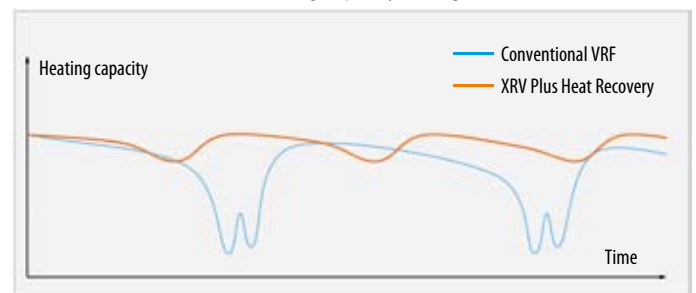

PROJECT VRF R410A

XRV MULTI SYSTEM - FULL DC INVERTER

XRV PLUS HEAT RECOVERY

Heat recovery - 3 pipes

FAN AND GRILLE

Outdoor unit heat exchangers are divided in two parts, a left and right structure, so that there are two independent circuits in one outdoor unit.

Each outdoor unit has two fans, which allow control over each heat exchanger structure individually.

PRESSURE HEAD UP TO 20 Pa

The available pressure head up to 20 Pa allows users to "hide" the outdoor units from view and to duct the outlet air.

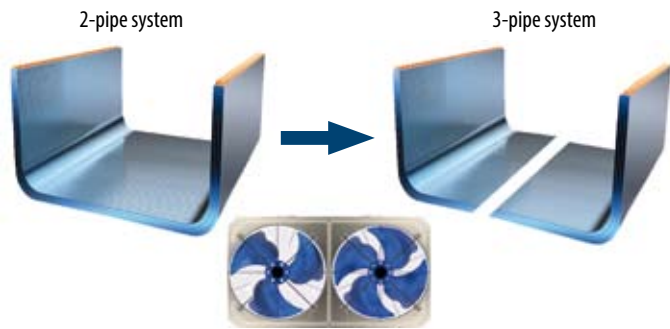

BRANCH PIPE KIT

BRANCH PIPES DOWNSTREAMS OF THE FIRST INDOOR UNIT	
Code	A - Capacity of the connectible indoor units (kW)
DIS-22-1RB	$A < 16.6$
DIS-180-1RB	$16.6 \leq A < 33.0$
DIS-371-1RB	$33.0 \leq A < 66.0$
DIS-540-1RH Plus	$66.0 \leq A < 92.4$
DIS-1344-1RH Plus	$92.0 \leq A < 135.0$

BRANCH PIPE KIT FOR OUTDOOR UNIT CONNECTION	
Code	Outdoor units
DOS 2-1RH Plus	2 Outdoor unit KITS
DOS 3-1RH Plus	3 Outdoor unit KITS
DOS 4-1RH Plus	4 Outdoor unit KITS
OH-BAL-KT*	T-shaped fitting for oil parallel pipe

* Included in DOS 3-1H Plus & DOS 4-1H Plus KITS.

INDOOR UNIT CONNECTION SYSTEM

Indoor units are connected to flow dividers. Up to 4 indoor units (max 16 kW) can be connected to each output. The units connected to each output can operate in different modes from those connected to another output. All indoor units connected to one output can only operate in the same mode.

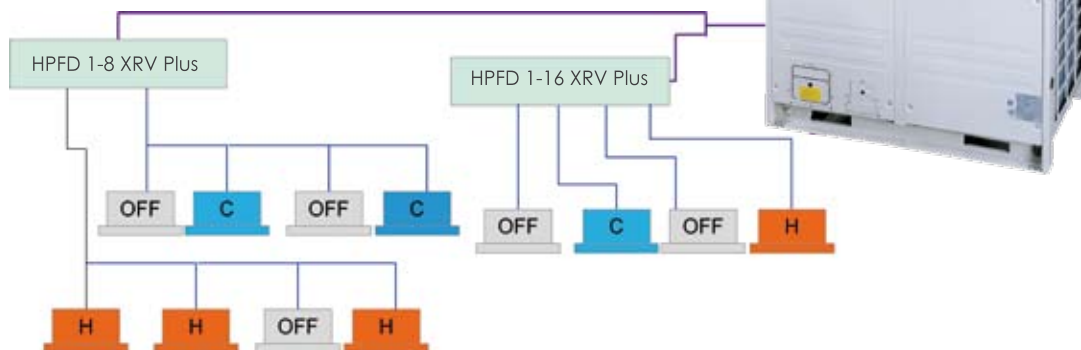

PROJECT VRF R410A

XRV MULTI SYSTEM - FULL DC INVERTER

XRV PLUS HEAT RECOVERY

Heat recovery - 3 pipes

Model / Combination		HCSRU 2524 XRV-1 Plus	HCSRU 2804 XRV-1 Plus	HCSRU 3354 XRV-1 Plus	HCSRU 4004 XRV-1 Plus	HCSRU 4504 XRV-1 Plus	
Power	HP	8	10	12	14	16	
Rated cooling capacity (1)	kW	25.2	28.0	33.5	40.0	45.0	
Rated heating capacity (2)	kW	27.0	31.5	37.5	40.0	45.0	
Electrical data							
Power supply	Volt/Hz/Ph	380-415/50/3					
Electric consumption in cooling mode (fully operational)	kW / A	5.97	6.75	9.28	11.49	14.20	
Electric consumption in heating mode (fully operational)	kW / A	5.02	6.21	9.24	9.76	11.90	
EER performance coefficient in cooling mode	w/w	4.22	4.15	3.61	3.48	3.17	
COP performance coefficient in heating mode	w/w	5.38	5.07	4.06	4.10	3.78	
Refrigerant circuit/features							
Refrigerant	type	R 410A					
DC Inverter compressor	no. / type	1 / Scroll DC Inverter HITACHI			2 / Scroll DC Inverter HITACHI		
Fan air flow	min/max	10675 / 12000			12875 / 15000		
Sound pressure level at 1 m	min/max	55/57			58/60		
Power level	min/max	79			88		
Refrigerant connections (3)	Liquid	Ø mm (inch)	9.53 (3/8)			12.7 (1/2)	15.9 (5/8)
	Low pressure gas	Ø mm (inch)	22.2 (7/8)			25.4 (1)	28.6 (9/8)
	High pressure gas	Ø mm (inch)	19.1 (3/4)			22.2 (7/8)	
	High pressure parallel gas	Ø mm (inch)	19.1 (3/4)			19.1 (3/4)	
	Parallel oil	Ø mm (inch)	6.35 (1/4)			6.35 (1/4)	
Max pipe length	m	1000					
Max height difference between indoor units	m	30					
Max height difference between outdoor and indoor units	m	70 (outdoor unit up high) - 110 (outdoor unit down low)					
Operating temp. range in cooling mode	°C / DB	-5° C / 43° C					
Operating temp. range in heating mode	°C / WB	-20° C / 24° C					
Operating temp. range in mixed cooling/heating mode	°C / WB	-5° C / 24° C					
Connectable indoor units	no.	13	16	20	23	26	
Capacity of connected indoor unit	%	50 - 130					
Dimensions and weight							
Dimensions (LxHxD) (4)	mm	1250x1615x765					
Net weight	Kg	255				303	

Model / Combination		HCSRU 2804 XRV-1 Plus HCSRU 2804 XRV-1 Plus HCSRU 4004 XRV-1 Plus	HCSRU 2804 XRV-1 Plus HCSRU 2804 XRV-1 Plus HCSRU 4504 XRV-1 Plus	HCSRU 2804 XRV-1 Plus HCSRU 3354 XRV-1 Plus HCSRU 4504 XRV-1 Plus	HCSRU 2804 XRV-1 Plus HCSRU 4004 XRV-1 Plus HCSRU 4504 XRV-1 Plus	HCSRU 4004 XRV-1 Plus HCSRU 4004 XRV-1 Plus HCSRU 4004 XRV-1 Plus	HCSRU 4004 XRV-1 Plus HCSRU 4004 XRV-1 Plus HCSRU 4504 XRV-1 Plus
Power	HP	34 (10+10+14)	36 (10+10+16)	38 (10+12+16)	40 (10+14+16)	42 (14+14+14)	44 (14+14+16)
Rated cooling capacity (1)	kW	96.0	101.0	106.5	113.0	120.0	125.0
Rated heating capacity (2)	kW	103.0	108.0	114.0	116.5	120.0	125.0
Electrical data							
Power supply	Volt/Hz/Ph	380-415/50/3					
Electric consumption in cooling mode (fully operational)	kW / A	24.99	27.70	30.23	32.44	34.47	37.18
Electric consumption in heating mode (fully operational)	kW / A	22.18	24.32	27.35	27.87	29.28	31.42
EER performance coefficient in cooling mode	w/w	3.84	3.65	3.52	3.48	3.48	3.36
COP performance coefficient in heating mode	w/w	4.64	4.44	4.17	4.18	4.10	3.98
Refrigerant circuit/features							
Refrigerant	type	R 410A					
DC Inverter compressor	no. / type	4 / Scroll DC Inverter HITACHI			5 / Scroll DC inv. HIT.		6 / Scroll DC inverter HITACHI
Fan air flow	min/max	10675 / 39000			10675 / 40000		10675 / 42000
Sound pressure level at 1 m	min/max	55/65			55/66		56/67
Power level	min/max	47/57			47/58		48/59
Refrigerant connections (3)	Liquid	Ø mm (inch)	19.1 (3/4)				
	Low pressure gas	Ø mm (inch)	41.3 (1 5/8)				
	High pressure gas	Ø mm (inch)	34.9 (1 3/8)				
	High pressure parallel gas	Ø mm (inch)	19.1 (3/4)				
	Parallel oil	Ø mm (inch)	6.35 (1/4)				
Max pipe length	m	1000					
Max height difference between indoor units	m	30					
Max height difference between outdoor and indoor units	m	70 (outdoor unit up high) - 110 (outdoor unit down low)					
Operating temp. range in cooling mode	°C / DB	-5° C / 43° C					
Operating temp. range in heating mode	°C / WB	-20° C / 27° C					
Operating temp. range in mixed cooling/heating mode	°C / WB	-5° C / 27° C					
Connectable indoor units	no.	56	59	63	64	64	64
Capacity of connected indoor unit	%	50 - 130					
Dimensions and weight							
Dimensions (Lx Hx D) (4)	mm	3950x1615x765					
Net weight	Kg	813		861		909	

(1) Cooling capacity tested in accordance with ISO 5151 Standards; outdoor temperature 35°C DB, 24°C WB and indoor temperature 27°C DB, 19°C WB.

(2) Heating capacity tested in accordance with ISO 5151 Standards; outdoor temperature 7°C DB, 6°C WB and indoor temperature 20°C DB, 15°C WB.

(3) When several outdoor units are paired the diameters indicated refer to the section up to the first branch, with a length equivalent or less than 90m.

(4) Space between the paired units = 100 mm.

PROJECT VRF R410A

XRV MULTI SYSTEM - FULL DC INVERTER

XRV PLUS HEAT RECOVERY

Heat recovery - 3 pipes

HCSRU 2524 XRV-1 Plus HCSRU 2804 XRV-1 Plus	HCSRU 2804 XRV-1 Plus HCSRU 2804 XRV-1 Plus	HCSRU 2804 XRV-1 Plus HCSRU 3354 XRV-1 Plus	HCSRU 2804 XRV-1 Plus HCSRU 4004 XRV-1 Plus	HCSRU 2804 XRV-1 Plus HCSRU 4504 XRV-1 Plus	HCSRU 4004 XRV-1 Plus HCSRU 4004 XRV-1 Plus	HCSRU 4004 XRV-1 Plus HCSRU 4504 XRV-1 Plus	HCSRU 4504 XRV-1 Plus HCSRU 4504 XRV-1 Plus
18 (8+10)	20 (10+10)	22 (10+12)	24 (10+14)	26 (10+16)	28 (14+14)	30 (14+16)	32 (16+16)
53.2	56.0	61.5	68.0	73.0	80.0	85.0	90.0
58.5	63.0	69.0	71.5	76.5	80.0	85.0	90.0
380-415/50/3							
12.72	13.5	16.03	18.24	20.95	22.98	25.69	28.40
11.23	12.42	15.45	15.97	18.11	19.52	21.66	23.8
4.18	4.15	3.84	3.73	3.48	3.48	3.31	3.17
5.21	5.07	4.47	4.48	4.22	4.10	3.92	3.78
R 410A							
2 / Scroll DC Inverter HITACHI		3 / Scroll DC Inverter HITACHI			4 / Scroll DC Inverter HITACHI		
10675 / 24000		10675 / 25000			10675 / 27000		12875 / 30000
55/61		55/62			55/63		56/64
47/53		47/54			47/55		48/56
15.9 (5/8)		15.9 (5/8)			19.1 (3/4)		19.1 (3/4)
31.8 (1 1/4)		31.8 (1 1/4)			34.9 (1 3/8)		34.9 (1 3/8)
28.6 (9/8)		28.6 (9/8)			28.6 (9/8)		28.6 (9/8)
19.1 (3/4)		19.1 (3/4)			19.1 (3/4)		19.1 (3/4)
6.35 (1/4)		6.35 (1/4)			6.35 (1/4)		6.35 (1/4)
1000							
30							
70 (outdoor unit up high) - 110 (outdoor unit down low)							
-5°C / 43°C							
-20°C / 24°C							
-5°C / 24°C							
29	33	36	39	43	46	50	53
50 - 130							
2600x1615x765							
510				558		606	

HCSRU 4004 XRV-1 Plus HCSRU 4504 XRV-1 Plus HCSRU 4504 XRV-1 Plus	HCSRU 4504 XRV-1 Plus HCSRU 4504 XRV-1 Plus HCSRU 4504 XRV-1 Plus	HCSRU 2524 XRV-1 Plus HCSRU 2804 XRV-1 Plus HCSRU 4504 XRV-1 Plus	HCSRU 2804 XRV-1 Plus HCSRU 2804 XRV-1 Plus HCSRU 4504 XRV-1 Plus	HCSRU 2804 XRV-1 Plus HCSRU 3354 XRV-1 Plus HCSRU 4504 XRV-1 Plus	HCSRU 2804 XRV-1 Plus HCSRU 4004 XRV-1 Plus HCSRU 4504 XRV-1 Plus	HCSRU 4004 XRV-1 Plus HCSRU 4004 XRV-1 Plus HCSRU 4504 XRV-1 Plus	HCSRU 4004 XRV-1 Plus HCSRU 4004 XRV-1 Plus HCSRU 4504 XRV-1 Plus	HCSRU 4004 XRV-1 Plus HCSRU 4504 XRV-1 Plus HCSRU 4504 XRV-1 Plus	HCSRU 4504 XRV-1 Plus HCSRU 4504 XRV-1 Plus HCSRU 4504 XRV-1 Plus
46 (14+16+16)	48 (16+16+16)	50 (8+10+16+16)	52 (10+10+16+16)	54 (10+12+16+16)	56 (10+14+16+16)	58 (14+14+14+16)	60 (14+14+16+16)	62 (14+16+16+16)	64 (16+16+16+16)
130.0	135.0	143.2	146.0	151.5	158.0	165.0	170.0	175.0	180.0
130.0	135.0	148.5	153.0	159.0	161.5	165.0	170.0	175.0	180.0
380-415/50/3									
39.89	42.6	41.12	41.9	44.43	46.64	48.67	51.38	54.09	56.8
33.56	35.7	35.03	36.22	39.25	39.77	41.18	43.32	45.46	47.6
3.26	3.17	3.48	3.48	3.41	3.39	3.39	3.31	3.24	3.17
3.87	3.78	4.24	4.22	4.05	4.06	4.01	3.92	3.85	3.78
R 410A									
6 / Scroll DC inverter HITACHI			7 / Scroll DC inv. HITA.			8 / Scroll DC inv. HITA.			
12875 / 45000		10675 / 54000		10675 / 55000		10675 / 57000		12875 / 60000	
56/67		56/68		56/68		56/68		55/69	
48/59		48/60		48/60		48/60		47/61	
19.1 (3/4)		19.1 (3/4)		22.2 (7/8)		22.2 (7/8)		22.2 (7/8)	
41.3 (1 5/8)		41.3 (1 5/8)		44.5 (1 3/4)		44.5 (1 3/4)		44.5 (1 3/4)	
34.9 (1 3/8)		34.9 (1 3/8)		38.1 (1 1/2)		38.1 (1 1/2)		38.1 (1 1/2)	
19.1 (3/4)		19.1 (3/4)		19.1 (3/4)		19.1 (3/4)		19.1 (3/4)	
6.35 (1/4)		6.35 (1/4)		6.35 (1/4)		6.35 (1/4)		6.35 (1/4)	
1000									
30									
70 (outdoor unit up high) - 110 (outdoor unit down low)									
-5°C / 43°C									
-20°C / 27°C									
-5°C / 27°C									
64	64	64	64	64	64	64	64	64	64
50 - 130									
3950x1615x765			5300x1615x765				5300x1615x765		
909			1116			1164		1212	

- (1) Cooling capacity tested in accordance with ISO 5151 Standards; outdoor temperature 35°C DB, 24°C WB and indoor temperature 27°C DB, 19°C WB.
- (2) Heating capacity tested in accordance with ISO 5151 Standards; outdoor temperature 7°C DB, 6°C WB and indoor temperature 20°C DB, 15°C WB.
- (3) When several outdoor units are paired the diameters indicated refer to the section up to the first branch, with a length equivalent or less than 90m.
- (4) Space between the paired units = 100 mm.