

2026 GENERAL CATALOGUE

hokkaido.it

HO
KK
AI
DO

Experience makes technology

GENERAL CATALOGUE HOKKAIDO 2026

Hokkaido, a leading brand in the air conditioning market in Italy and Europe, stands out for its ability to support every supply request and satisfy the most demanding customers.

Proprietary brand products are known for their excellent value for money and reliability in use.

The advantageous quality/price ratio, pre- and post-sales services, wide range of spare parts and accessories that can be ordered online, and integrated logistics management are Hokkaido's strong points.

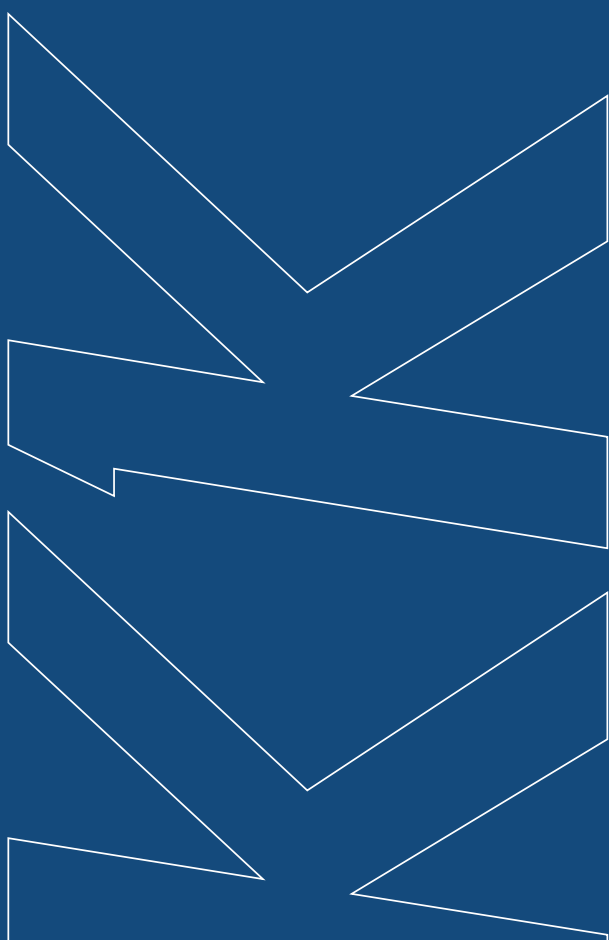



TECHNOLOGY AND PROFESSIONALISM AT YOUR SERVICE

Hokkaido stands for reliable products with a high quality-price ratio.

Air conditioning systems that stand out for savings and efficiency, in line with the regulations and needs of the new energy transition.

A wide range of styles and capacities to suit the needs of every environment.



HOKKAIDO

EXPERIENCE MAKES **TECHNOLOGY**

OVER TWENTY YEARS OF EXPERIENCE

The Hokkaido brand is a leader in Italy and Europe in the air conditioning sector for residential, commercial and industrial applications, its success has been built step by step in over twenty years of activity.





EXPERIENCE THAT GUIDES THE FUTURE

**TECHNOLOGICAL RESEARCH, A LOVE OF CHALLENGE
AND THE ABILITY TO INTERPRET THE FUTURE ARE OUR
ENTREPRENEURIAL HERITAGE**

These principles are the foundation of a history that has been developing for over 40 years, of a commitment that has evolved in the pursuit of excellence and continuous improvement.

TERMAL GROUP

Termal is a commercial group that was founded in the 1980s. A history that has developed over more than 40 years of dynamic activity, a commitment that has evolved in the pursuit of excellence and continuous improvement. Termal is currently a group consisting of a network of companies and is a leading player in the Italian and European climate and comfort sector.

THE HOKKAIDO BRAND

The origins of the Hokkaido brand date back to the end of 1998, the year in which the Termal Group began distributing a selection of products for residential air conditioning, whose affordable. The distribution of Hokkaido products immediately had a widespread development throughout Italy, through the channel of professional installers and wholesalers.

Since the early 2000s, the international network of dealers and distributor partners has developed rapidly, thanks above all to the variety and reliability of the services offered.

TERMAL QUALITY

- Direct logistics;
- Academy for continuous training;
- Extensive network of service centres;
- In-house technical office for product development;
- Pre- and post-sales service.

PRE-SALES AND AFTER-SALES SERVICE

TERMAL ASSISTANCE PORTAL, THE REFERENCE POINT FOR ASSISTANCE

The Termal Assistance Portal provides centralised and efficient technical assistance for products.

The platform can be accessed at **www.assistentzatermal.it**; customers and technical assistance centres can access it to submit their support requests through a clear interface, personalised access and linear operational flows.

An environment where, through simple workflows, support requests can be submitted and the necessary documentation accessed.

Each request is automatically forwarded to the relevant department, ensuring effective management and optimised response times.



Centralised access

A single portal for all support needs.



Simplified experience

Intuitive interface for all types of users, with guided paths.



Efficiency and speed

System that simplifies communication with the relevant departments and reduces response times.



Integrated management

Each flow generates a notification to the correct department and links to secondary portals (manuals, spare parts).

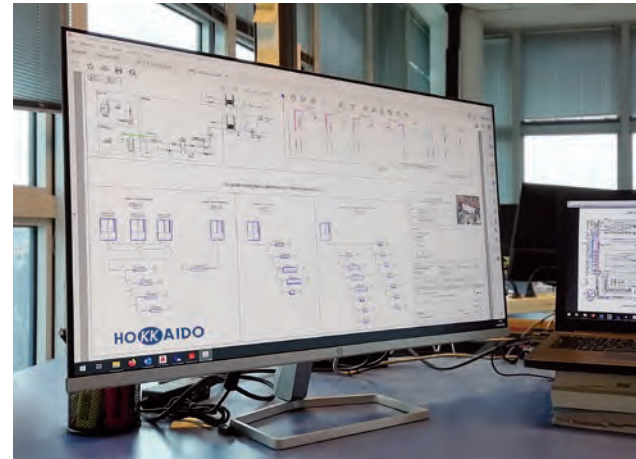
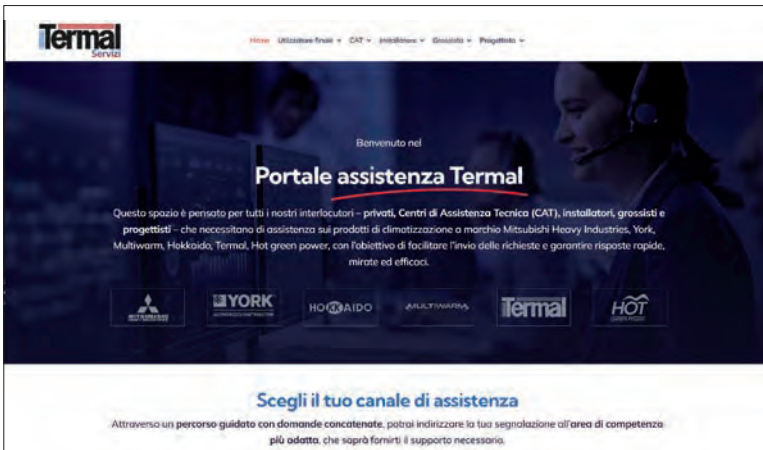

ADVANTAGES FOR INSTALLERS, DESIGNERS AND WHOLESALERS

The portal dedicated to **professional operators** offers a complete set of tools for every phase: from design to commissioning, right through to after-sales support.

Each profile – installer, designer or wholesaler – finds **technical resources, specific modules and support materials** that facilitate daily work, reduce response times and guarantee a high level of service to the end customer.



Start-up and after-sales service

Just a few clicks to send us your request for product commissioning or after-sales assistance on already installed products.



Spare parts management and after-sales service

Dedicated area for requesting original spare parts and support for products that have already been installed.



Documentation requests

Quickly obtain manuals, diagrams, technical specifications and official support materials.



Design specifications

Tools for defining technical requirements, system diagrams and design configurations.

ADVANTAGES FOR CATS AND SELF-SERVICE CUSTOMERS

The portal offers CATs and self-service customers a structured environment in which to operate efficiently and independently. The features are designed to meet the **needs of those who work with the product** on a daily basis, providing direct specialist technical support and access to the most up-to-date documentation.

To streamline the compilation of requests, these users can **log in**.



Specialised technical support

Access to dedicated channels to request in-depth assistance on complex issues or technical interventions.



Access to technical documentation

Manuals, certifications and technical specifications are always available and up to date.



Spare parts management

Reserved area for selecting and requesting original spare parts needed for field interventions.

TERMAL ACADEMY TRAINING

TRAINING THAT BECOMES OPERATIONAL EXPERTISE. IN BOLOGNA, AT THE HEART OF THE TERMAL GROUP

The Termal Academy is the training department of the Termal Group: a team of engineers and specialised technicians who transfer practical know-how on air conditioning, heating and domestic hot water production systems from the brands distributed by the Group on a daily basis.

An environment where, through simple flows, you can submit requests for assistance and access the necessary documentation.

We are located in Bologna, where theory meets real-life systems in operation and training becomes performance in the field.



Termal Academy

Who it is aimed at

Installers, designers, specialised technicians. Professionals who want to work to the highest standards, keep up to date with the latest developments and transform technical expertise into value for the customer and new business opportunities.

Our method

- Theory + practice: each course combines lectures, demonstrations and tests on working systems.
- Operational approach: focus on installation, assistance, maintenance and fault diagnosis.
- Continuous updating: programmes always aligned with new products, technological developments and regulatory changes.

The headquarters and laboratories

At our Bologna headquarters, you will find:

- **Theory classrooms** for structured in-depth study.
- **Demonstration and practical classrooms** with real systems from the various product families (residential, commercial, VRF and hydronic systems) and related control instruments.

This is where you really learn: by touching, measuring and configuring.





HVAC training content

- Refrigeration circuit and best installation practices.
- Fault diagnosis and service procedures.
- Design of **VRF systems** or **air-water heat pumps**.
- Use of **sizing software**.
- Regular updates on **industry regulations**.

The principles that guide us

Trust, technology, evolution, quality, continuous training. These are our five guiding principles: we believe in people and their development. Experienced professionals are at your side to tackle the challenges of everyday work and always stay one step ahead.

Strategies for the future

The TERMAL Academy offers regular, highly specialised programmes on innovative HVAC products and solutions. Not just technical skills: we also focus on marketing and sales techniques to improve customer relations and communication, so that we can truly meet their needs.

What you take home

- **Up-to-date** and immediately **applicable** operational skills.
- **Certificate of attendance** and **complete technical** handouts for each module.
- A network of specialists with whom you can continue to exchange ideas even after the course.



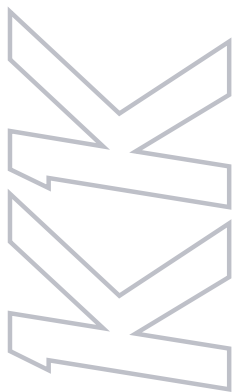

THE DISTRIBUTORS NETWORK

HOKKAIDO DISTRIBUTORS NETWORK

Hokkaido products are distributed by Termal Sales on the Italian and international markets through specialized distribution networks, with an integrated logistics service.

Hokkaido has all the experience and network of resources needed to offer versatile and high-tech heating, cooling and domestic hot water solutions.

Visit the official website www.hokkaido.it

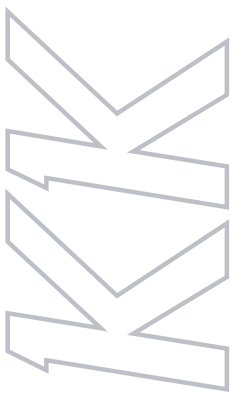

ADVANCED LOGISTICS

SPARE PARTS ONLINE AVAILABLE IN 24 HOURS

The success of the brand comes from the great attention to customer needs, with particular reference to the logistics organization, which has always been a point of excellence of the Termal Group: rapid deliveries throughout the community, a vast assortment of spare parts and accessories that can be ordered online and available in 24 hours. All this allows customers great operational and commercial flexibility and strong competitiveness in the presence of the various local markets.

OUR HEADQUARTERS

The headquarters of Termal Sales is in Bologna, at the operational center of Termal Group. A modern complex (4,000 square meters of offices and 4,500 square meters of area for product storage) is the operational hub of commercial, logistics and administrative activities.

This center also brings together technical-commercial assistance and training activities, managed directly to ensure high quality standards. The plant, built in a strategic position with respect to the airport and the motorway junction, is constructed according to the most modern architectural concepts for logistics.



GENERAL CONTENTS **2026**

- 15** RESIDENTIAL &
COMMERCIAL R32
- 45** RESIDENTIAL MULTISPLIT
COMBINATIONS
- 49** PROJECT VRF R410A
FULL DC INVERTER
- 57** HEATING
- 69** CONTROLS

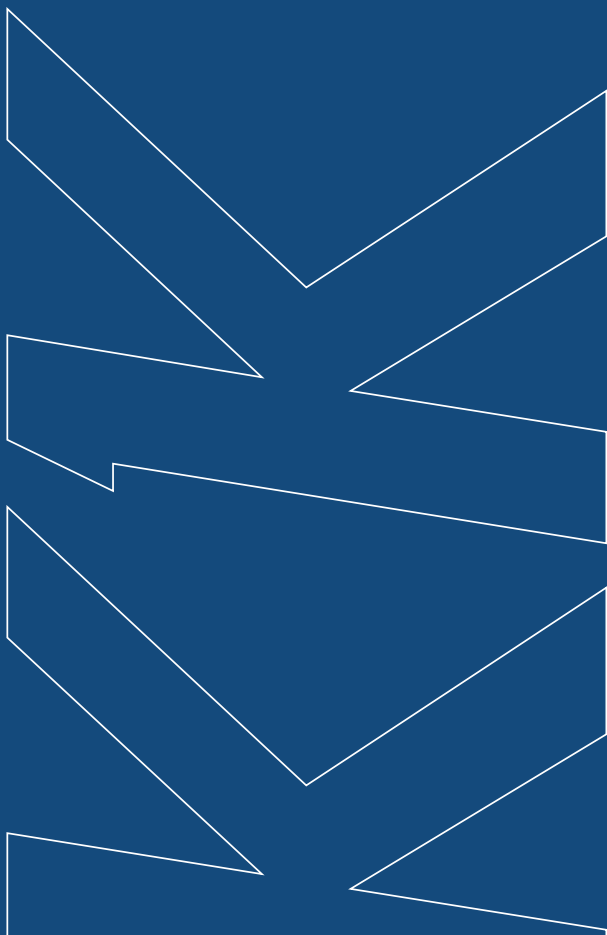

RESIDENTIAL & COMMERCIAL R32



RESIDENTIAL & COMMERCIAL R32, WELLBEING FOR YOUR HOME

The most demanding customers, attentive to technological evolution, the benefits that derive from it and respect for the environment, will find a concrete answer in the new line, which offers a choice in line with the needs and evolutions of the market.

18 Line-up

MONOSPLIT

20 Mono and Multi wall models

24 LUMINA Wall

26 AIKO Wall

28 AIKO S Wall

30 Compact Cassette

32 Slim Cassette

34 Ducted medium static pressure

36 Console

38 Floor/Ceiling

MULTISPLIT

41 Line up

42 Outdoor units

43 Indoor units

45 **COMBINATIONS**

R32 WELLBEING FOR PEOPLE AND PLANET

ADVANTAGES OF R32

Nowadays, environmental protection is considered of primary importance by both the user and the professional. Choosing an air conditioner with R32 refrigerant allows you to obtain excellent comfort in both cooling and heating, reducing polluting emissions.

The most relevant aspect of R32 gas is its GWP value, equal to 675, which allows the creation of systems containing up to 7.4 kg of gas without exceeding the threshold that requires leak control and keeping an equipment register, a threshold that for an R410A gas is already exceeded by 2.4 kg of gas.

- it's eco-friendly;
- **it is non-toxic;**
- it is slightly flammable;
- it is not harmful and does not pose a risk to the ozone layer;
- it is very efficient.

WHY CHOOSE R32

The specific name of R32 gas is difluoromethane. It is currently present among the fluorinated gases with a low GWP value, equal to 675.

There is no obligation to replace R410A gas, which therefore remains regularly on the market, except in monosplit applications with refrigerant < 3 kg where, from 2025, the use of gas with GWP < 750 will be mandatory for new installations.

There are some limitations in particular conditions of use that must be considered in accordance with the regulations in force.

STORAGE, STANDARDS AND DESIGN

When storing units containing R32, it may be necessary, based on the quantities stored, to review the Fire Prevention Certificate (DPR 151/2011) to ensure the validity of your insurance guarantee. The transport of dangerous goods is regulated by D.GLS 35/2010. R32 has been classified as slightly flammable by ISO 817 and as such has no stringent limitations in road transport (current ADR), maintaining strict regulations in maritime transport (current IMDG) and aeronautical transport (current IATA).

The EN 378:2016 standard also regulates the applications of appliances that use R32 gas; the maximum concentration limits of the gas in residential applications must always be verified with particular attention to multisplit systems that can potentially concentrate (in the event of leaks) high quantities of refrigerant in small environments. **R32 gaz is heavier than air and in the event of a leak it accumulates at the bottom;** therefore, indoor units follow different regulatory parameters depending on the type of application.

Installation in public buildings is regulated by specific regulations relating to the application of appliances with flammable gases, such as: hotels DM 09/04/1994, shopping centres DM 27/07/2010, buildings for entertainment DM 19/08/1996, hospitals DM 18/09/2012, schools DM 26/08/1992, offices DM 22/02/2006, children's games DM 16/07/2014, airports DM 07/07/2014, interports DM 18/07/2014.

The design, installation and maintenance of appliances with R32 gaz are regulated by the following standards: DM 37/2008, provisions on the installation of systems inside buildings; DGLS 81/2008, text on health and safety at work; F-gas 517/2014, regulation of fluorinated gases; DPR 151/2011, regulation of procedures relating to fire prevention; EN 378:2016, refrigeration systems and heat pumps (requirements for the safety of systems).

With the Ministerial Decree of 10 March 2020 and the subsequent Circular DCPREV 9833 of 22 July 2020 by the Fire Brigade, the technical provisions are updated to allow the possibility of using, in air conditioning and conditioning systems, machines equipped with refrigerants classified as A1 or A2L, thus overcoming the restriction of using only non-toxic or non-flammable fluids.

However, it is recommended to carefully check the regulations in force when using equipment containing R32 gas. Failure to comply with these regulations makes designers and installers of equipment with R32 assume direct legal responsibility for the application of the equipment itself.

CONTROL THE CLIMATE WHERE AND WHEN YOU WANT

MORE COMFORT & SAVINGS

With Hokkaido WiFi you can control the climate remotely.



FOR EXPERIENCED SAVERS

Hokkaido Wi-Fi allows you to save money and energy. For example, through Hokkaido apps you can turn on the air conditioning system remotely to gradually heat or cool your home or business.

DEDICATED APP

The dedicated app provides information about the air conditioner and its operation. It also allows you to:

- change temperature settings;
- keep energy consumption under control;
- program the air conditioner;
- check that the system is working correctly.



LINE UP R32 MONOSPLIT

	kW	2.60	3.50	5.30	7.10
LUMINA					
Wall 		✓	✓	✓	✓
AIKO					
Wall 		✓	✓	✓	✓
AIKO S					
Wall 		✓	✓		
COMMERCIAL					
Compact Cassette 			✓	✓	
Slim Cassette 84x84 					✓
Console 			✓	✓	
Ducted medium static pressure 			✓	✓	✓
Floor/ceiling 				✓	✓
Outdoor units Wall LUMINA					
Outdoor units Wall AIKO					
Outdoor units Wall AIKO S					
Outdoor units Commercial					

Yields and consumption are measured under the following test conditions:
 heating O.T. 7° C DB, 6° C WB - I.T. 20° C DB; cooling: O.T. 35° C DB, 24° C WB - I.T. 27° C DB, 19° C WB (ISO T1).



WALL RANGE FEATURES

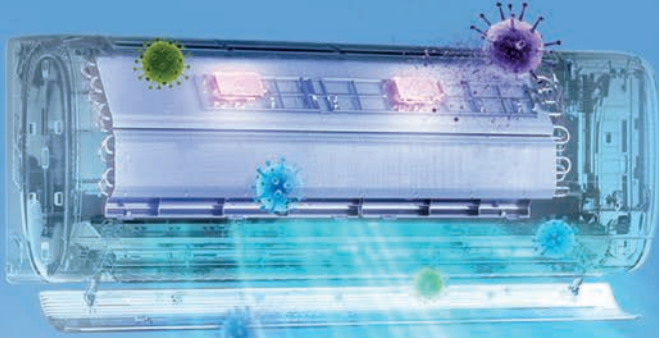

UVC STERILIZATION INCLUDED AS STANDARD (AIKO S)

-99.99%

Dust mites, influenza viruses, HFMD, mold, pet germs.

Sterilization

AIKO S releases specific UV wavelengths, which penetrate the core of microorganisms, eliminating them with an efficiency of 99.99%.

Neutralizes viruses, bacteria and molds

by damaging their proteins and DNA.

MULTIPORE TECHNOLOGY (AIKO/AIKO S)

1935 micro holes on the outlet flap of AIKO and AIKO S allow a smooth and gentle flow of air, avoiding annoying jets of air.

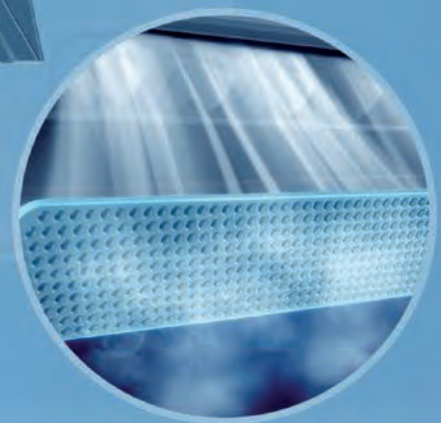
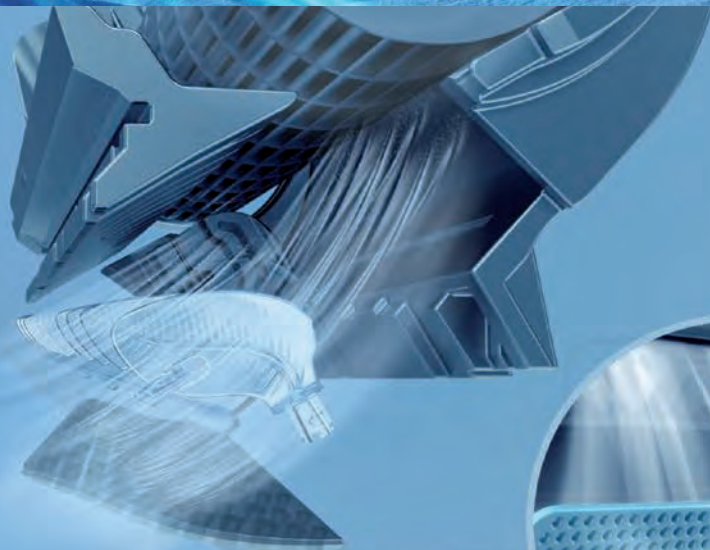

Completely closed

Semi-closed

Intelligent flow management through micro-perforated flap

The unit recognizes changes in room temperature and autonomously chooses which of the two delivery configurations to use.

WALL RANGE FEATURES

EFFECTIVE AGAINST VIRUSES AND BACTERIA

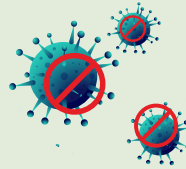

-99.9%

Influenza virus, HFMD,
Escherichia coli,
Staphylococcus aureus.



Self-Cleaning function

It determines the self-cleaning of the exchanger, drying it from any condensation residues. It prevents the formation of mold and bad odors. The sterilization process guarantees the neutralization of 99.9% of the bacteria present inside it.

Filtration system

- o purifies and deodorizes the air;
- o filters pollen, bacteria and odors;
- o purifies and prevents the spread of viruses and bacteria;
- o eliminates harmful dust.

HD (High Density) Filter

Positioned on the top of the unit, easily removable from its housing, it retains dust and hair. It is easy to clean.

SMART MANAGEMENT WITH WIFI

All the functions, always at hand, with the app.

The convenience of setting the temperature before arriving home, to find the desired comfort as soon as you return.



WALL RANGE FEATURES

ELECTRIC RESISTANCE IN THE OUTDOOR UNIT BODY

(AIKO/AIKO S)

The electrical resistance in the body of the outdoor unit prevents it from freezing, prolonging the useful life of the machine and improving its performance.



HEAT EXCHANGER TREATED WITH ANTI-CORROSION COATING

Anti-corrosion treatment for external and internal unit heat exchanger, gives the heat exchanger resistance to rain, salt and other corrosive elements.

It also prevents the proliferation of bacteria and improves heat exchange efficiency.



WALL RANGE FEATURES

4D AIR FLOW (AIKO S)

AIKO S spreads air evenly to reach every corner of the room. Four-dimensional air conditioning with horizontal and vertical oscillation action ensures better airflow and provides uniform cooling and heating.

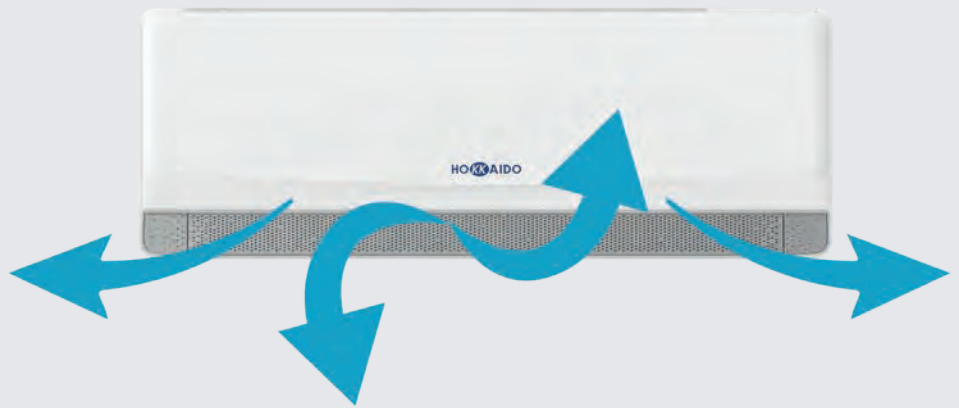

OUTDOOR UNIT'S PCB COOLED BY REFRIGERANT

In Hokkaido wall mounted units the PCB is cooled by refrigerant flow, the PCB temperature is 15°C lower than the classic method.

Unlike traditional air conditioners, where the PCB of the outdoor unit is cooled by air flow, which is inefficient and not very effective.

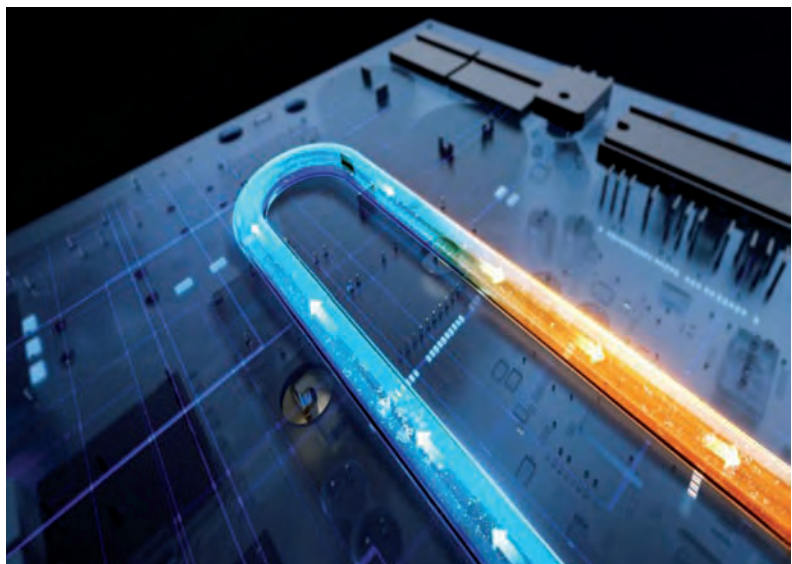

LUMINA

A++
in cooling

A+
in heating



PCB OF THE OUTDOOR UNIT COOLED BY REFRIGERANT



EFFECTIVE AGAINST VIRUSES AND BACTERIA



SMART MANAGEMENT WITH WIFI II APP SMARTLIFE



HEAT EXCHANGER TREATED WITH ANTI-CORROSION COATING

6,6 ★

One of the highest SEER ratings in the market segment (average 2.5-3.5 kW)

4,1 TOP

SCOP highest in the market segment (average 2.5-3.5 kW)

50°C TOP

Outdoor temperature range in cooling mode up to 50°C

LUMINA is the air conditioner that achieves the best heating efficiency values in the market segment.

LUMINA has the highest outdoor temperature value at which cooling operation is guaranteed in the market segment (50°C)

The values shown are the result of an internal comparative analysis with the main competitors in the relevant market segment. Values updated in September 2025 based on data in the 2025 public catalogues. Ask your sales representative for more information.

KEY

TOP Top feature, the best data on the market

★ Silver feature, one of the best figures on the market

RESIDENTIAL & COMMERCIAL R32

LUMINA | WALL | HKEDS 260-350-530-710 ZA



App Smartlife

Remote control included



15-50°C in cooling
-15-30°C in heating

Auto restart
8°C function

I-Feel

Indoor unit model		HKEDS 260 ZA	HKEDS 350 ZA	HKEDS 530 ZA	HKEDS 710 ZA	
Outdoor unit model		HCNDS 260 ZA	HCNDS 350 ZA	HCNDS 530 ZA	HCNDS 710 ZA	
Type		DC-Inverter heat pump				
Control (supplied)		Remote control				
Wi-Fi module		Integrated				
Nominal data						
Nominal capacity (T=+35°C)	Cooling	kW	2.60 (0.60~3.10)	3.50 (0.80~4.10)	5.30 (1.30~5.70)	7.30 (1.80~7.40)
Nominal absorbed power (T=+35°C)		kW	0.80 (0.10~1.60)	1.08 (0.10~1.60)	1.63 (0.29~2.10)	2.20 (0.23~2.70)
Nominal energy efficiency coefficient		EER ¹	3.25	3.24	3.25	3.32
Nominal capacity (T=+7°C)	Heating	kW	2.61 (0.80~3.40)	3.80 (1.00~4.20)	5.30 (1.30~5.50)	7.30 (1.80~7.40)
Nominal absorbed power (T=+7°C)		kW	0.70 (0.30~1.50)	1.02 (0.30~1.60)	1.42 (0.25~1.80)	1.96 (0.23~2.53)
Nominal energy performance coefficient		COP ¹	3.73	3.73	3.73	3.72
Seasonal data						
Theoretical load (Pdesignc)	Cooling	kW	2.60	3.50	5.30	6.70
Seasonal energy efficiency index		SEER ²	6.10	7.00	6.80	6.90
Seasonal energy efficiency class		626/2011 ³	A++	A++	A++	A++
Annual energy consumption		kWh/a	150	173	273	340
Theoretical load (Pdesignh) @ -10°C	Heating (average weather conditions)	kW	2.10	2.70	4.00	5.30
Seasonal performance coefficient		SCOP ²	4.00	4.10	4.00	4.20
Seasonal energy efficiency (ηs)		%	157	161	157	165
Seasonal energy efficiency class		626/2011 ³	A+	A+	A+	A+
Annual energy consumption		kWh/a	735	922	1400	1766
Electrical data						
Power supply	Outdoor unit	Ph-V-Hz	1Ph - 220/240V - 50Hz			
Power cable		Type	3 x 2.5 mm ²		3 x 4 mm ²	
Wiring between I.U. and O.U.		no.	5	5	5	5
Nominal absorbed electric current	Cooling	A	3.70 (0.60~8.50)	4.80 (0.70~7.80)	7.80 (2.20~9.30)	10.00 (1.00~12.00)
	Heating	A	3.30 (0.20~8.50)	4.60 (1.50~8.00)	6.50 (2.00~8.00)	9.00 (1.00~11.00)
Max current		A	8.50	9.50	12.00	16.00
Max absorbed power		kW	1.60	1.90	2.50	3.40
Refrigerant circuit data						
Refrigerant ⁴		Type (GWP)	R32 (675)			
Q.ty of refrigerant pre-charge		Kg	0.46	0.60	0.85	1.30
Tons of CO2 equivalent		t	0.311	0.405	0.574	0.878
Liquid/gas refrigerant pipe diameter		mm (inches)	6.35(1/4") / 9.52(3/8")	6.35(1/4") / 9.52(3/8")	6.35(1/4") / 12.74(1/2")	6.35(1/4") / 15.88(5/8")
Max split length		m	20	20	20	25
Max difference in height I.U./O.U.		m	10	10	10	15
Split length without additional charge		m	5	5	5	5
Additional charge		g/m	20	20	30	30
Indoor unit specifications						
Dimensions	LxDxH	mm	716x193x285	768x201x299	917x218x318	1140x230x332
Net weight		Kg	7	8	10	13
Sound power level	Hi	dB(A)	52	53	59	62
Sound pressure level	S/H/M/L/Silence	dB(A)	39/35/32/31/21	40/36/33/32/22	46/41/38/36/25	49/44/41/39/27
Treated air volume (S/H/M/L/Silence)	Cooling	m ³ /h	550/490/430/370/250	650/570/515/460/330	900/730/650/550/410	1300/1150/1020/880/580
	Heating	m ³ /h	500/460/400/350/350	650/600/530/460/460	900/780/700/550/550	1250/1150/1020/880/880
Outdoor unit specifications						
Dimensions	LxDxH	mm	650x233x455	708x258x530	785x300x555	890x319x695
Net weight		Kg	18.5	22	27	39
Sound power level		dB(A)	59	62	62	64
Sound pressure level		dB(A)	44	44	44	46
Treated air volume		m ³ /h	1800	1800	2800	3600
Operating limits (outdoor temperature)	Cooling	°C	15~50			
	Heating	°C	-15~30			

1. Value measured according to the harmonised standard EN14511. 2. EU Regulation No. 206/2012 - - Value measured according to the harmonised standard EN14825. 3. EU Delegated Regulation No. 626/2011 on the new energy consumption labelling of air conditioners. 4. Refrigerant leakage contributes to climate change. When released into the atmosphere, refrigerants with a lower global warming potential (GWP) contribute less to global warming than those with a higher GWP. This appliance contains a refrigerant with a GWP of 675. Therefore, if 1 kg of this refrigerant were released into the atmosphere, the impact on global warming would be 675 times higher than 1 kg of CO₂, over a period of 100 years. Under no circumstances should the user attempt to intervene on the refrigerant circuit or disassemble the product. In case of need, always contact qualified personnel.

AIKO

TOP A+++
in cooling

TOP A+++
in heating

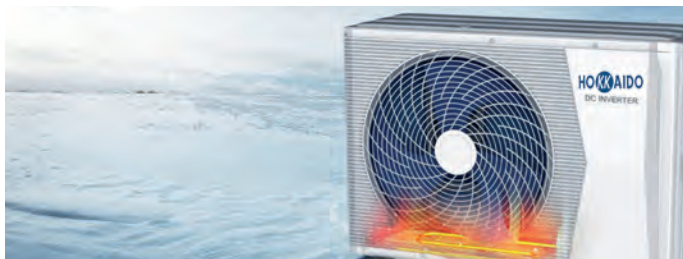

ELECTRICAL RESISTANCE IN THE OUTDOOR UNIT BODY



PCB OF THE OUTDOOR UNIT COOLED BY REFRIGERANT



MULTIPORE TECHNOLOGY **TOP**



SMART MANAGEMENT WITH WIFI APP SMARTLIFE



HEAT EXCHANGER TREATED WITH ANTI-CORROSION COATING



EFFECTIVE AGAINST VIRUSES AND BACTERIA

8,7 **TOP**

One of the highest SEER ratings in the market segment (average 2.5-3.5 kW)

4,7 **TOP**

SCOP highest in the market segment (average 2.5-3.5 kW)

53°C **TOP**

Outdoor temperature range in cooling mode up to 53°C

-25°C **TOP**

Outdoor temperature range in heating mode down to -25°C

AIKO is the air conditioner that achieves the best heating efficiency values in the market segment.

AIKO has the highest extreme temperature values for operating ranges in the market segment.

The values shown are the result of an internal comparative analysis with the main competitors in the relevant market segment. Values updated in September 2025 based on data in the 2025 public catalogues. Ask your sales representative for more information.

KEY

TOP Top feature, the best data on the market

★ Silver feature, one of the best figures on the market

RESIDENTIAL & COMMERCIAL R32

AIKO | WALL | HKEDS 261-351-531-711 ZA



Remote control included

App Smartlife



15-53°C in cooling
-25-30°C in heating

Multipore air outlet flap
Auto restart

8°C function
I-Feel

Indoor unit model			HKEDS 261 ZA	HKEDS 351 ZA	HKEDS 531 ZA	HKEDS 711 ZA
Outdoor unit model			HCNDS 261 ZA	HCNDS 351 ZA	HCNDS 531 ZA	HCNDS 711 ZA
Type			DC-Inverter heat pump			
Control (supplied)			Remote control			
Wi-Fi module			Integrated			
Nominal data						
Nominal capacity (T=+35°C)	Cooling	kW	2.70 (0.60~4.00)	3.50 (0.65~4.10)	5.40 (1.30~5.90)	7.20 (1.80~7.40)
Nominal absorbed power (T=+35°C)		kW	0.72 (0.10~1.20)	0.87 (0.13~1.55)	1.43 (0.29~1.95)	1.70 (0.23~2.30)
Nominal energy efficiency coefficient		EER ¹	3.75	4.02	3.78	4.24
Nominal capacity (T=+7°C)	Heating	kW	3.30 (0.80~4.20)	4.20 (0.93~4.20)	5.80 (1.30~6.10)	7.80 (1.80~8.00)
Nominal absorbed power (T=+7°C)		kW	0.80 (0.20~1.20)	1.06 (0.23~1.30)	1.33 (0.25~1.80)	2.10 (0.23~2.53)
Nominal energy performance coefficient		COP ¹	4.13	3.96	4.36	3.71
Seasonal data						
Theoretical load (Pdesignc)	Cooling	kW	2.70	3.50	5.40	6.10
Seasonal energy efficiency index		SEER ²	8.70	8.70	8.70	8.70
Seasonal energy efficiency class		626/2011 ³	A+++	A+++	A+++	A+++
Annual energy consumption		kWh/a	109	141	215	246
Theoretical load (Pdesignh) @ -10°C	Heating (average weather conditions)	kW	2.30	2.80	4.40	5.40
Seasonal performance coefficient		SCOP ²	4.70	4.70	4.60	4.60
Seasonal energy efficiency (ηs)		%	185	185	181	181
Seasonal energy efficiency class		626/2011 ³	A++	A++	A++	A++
Annual energy consumption		kWh/a	686	845	1339	1644
Electrical data						
Power supply	Outdoor unit	Ph-V-Hz	1Ph - 220/240V - 50Hz			
Power cable		Type	3 x 2.5 mm ²			3 x 4 mm ²
Wiring between I.U. and O.U.		no.	5	5	5	5
Nominal absorbed electric current	Cooling	A	3.30 (0.60~5.30)	4.20 (0.60~5.80)	6.40 (2.20~6.80)	7.90 (1.00~10.00)
	Heating	A	3.90 (1.00~5.30)	4.80 (1.00~6.30)	6.10 (2.00~8.00)	10.50 (1.00~11.00)
Max current		A	9.00	9.00	12.00	16.00
Max absorbed power		kW	1.60	1.50	2.40	3.20
Refrigerant circuit data						
Refrigerant ⁴		Type (GWP)	R32 (675)			
Q.ty of refrigerant pre-charge		Kg	0.55	0.60	1.03	1.20
Tons of CO2 equivalent		t	0.371	0.405	0.695	0.810
Liquid/gas refrigerant pipe diameter		mm (inches)	6.35(1/4") / 9.52(3/8")	6.35(1/4") / 9.52(3/8")	6.35(1/4") / 12.74(1/2")	6.35(1/4") / 15.88(5/8")
Max split length		m	20	20	20	25
Max difference in height I.U./O.U.		m	10	10	10	15
Split length without additional charge		m	5	5	5	5
Additional charge		g/m	20	20	30	30
Indoor unit specifications						
Dimensions	LxDxH	mm	768x201x299	827x201x299	1140x230x332	1140x230x332
Net weight		Kg	8	8.5	13.5	14
Sound power level	Hi	dB(A)	54	56	56	62
Sound pressure level	S/H/M/L/Silence	dB(A)	41/37/34/32/23	43/39/36/34/24	43/39/36/34/24	49/44/41/39/27
Treated air volume (S/H/M/L/Silence)	Cooling	m ³ /h	650/580/550/500/330	650/580/550/500/330	1060/900/800/650/550	1300/1200/1010/870/590
	Heating	m ³ /h	700/630/600/550/550	700/630/600/550/550	1000/900/790/650/640	1200/1030/930/870/870
Outdoor unit specifications						
Dimensions	LxDxH	mm	708x258x530	708x258x530	785x281x548	890x319x695
Net weight		Kg	22.5	24.5	28.5	41
Sound power level		dB(A)	61	62	63	65
Sound pressure level		dB(A)	48	49	50	52
Treated air volume		m ³ /h	1800	2300	2800	4900
Operating limits (outdoor temperature)	Cooling	°C	15~53			
	Heating	°C	-25~-30			

1. Value measured according to the harmonised standard EN14511. 2. EU Regulation No. 206/2012 - Value measured according to the harmonised standard EN14825. 3. EU Delegated Regulation No. 626/2011 on the new energy consumption labelling of air conditioners. 4. Refrigerant leakage contributes to climate change. When released into the atmosphere, refrigerants with a lower global warming potential (GWP) contribute less to global warming than those with a higher GWP. This appliance contains a refrigerant with a GWP of 675. Therefore, if 1 kg of this refrigerant were released into the atmosphere, the impact on global warming would be 675 times higher than 1 kg of CO₂ over a period of 100 years. Under no circumstances should the user attempt to intervene on the refrigerant circuit or disassemble the product. In case of need, always contact qualified personnel.

AIKO S

TOP A+++
in cooling

TOP A+++
in heating

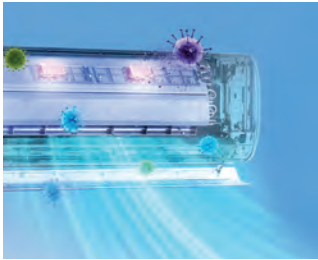

UVC STERILIZATION INCLUDED AS STANDARD



4D AIR FLOW

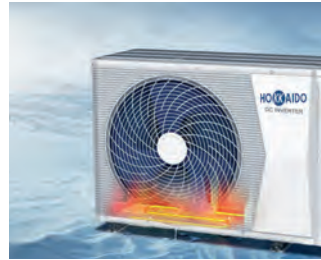

ELECTRICAL RESISTANCE IN THE OUTDOOR UNIT BODY

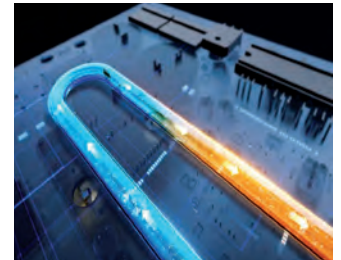

PCB OF THE OUTDOOR UNIT COOLED BY REFRIGERANT



MULTIPORE TECHNOLOGY **TOP**



SMART MANAGEMENT WITH WIFI APP SMARTLIFE



HEAT EXCHANGER TREATED WITH ANTI-CORROSION COATING



EFFECTIVE AGAINST VIRUSES AND BACTERIA

8,7 **TOP**

One of the highest SEER ratings in the market segment (average 2.5-3.5 kW)

AIKO S is the air conditioner that achieves the best heating efficiency values in the market segment.

4,7 **TOP**

SCOP highest in the market segment (average 2.5-3.5 kW)

53°C **TOP**

Outdoor temperature range in cooling mode up to 53°C unique on the market

AIKO S has the highest extreme temperature values for operating ranges in the market segment.

-25°C **TOP**

Outdoor temperature range in heating mode down to -25°C

The values shown are the result of an internal comparative analysis with the main competitors in the relevant market segment. Values updated in September 2025 based on data in the 2025 public catalogues. Ask your sales representative for more information.

KEY

TOP Top feature, the best data on the market

S Silver feature, one of the best figures on the market

RESIDENTIAL & COMMERCIAL R32

AIKO S | WALL | HKEDS 262-352 ZA



App Smartlife

Remote control included



15-53°C in cooling
25-30°C in heating

UVC Sterilizer
4D Air Flow

Multipore air outlet flap
Auto restart

8°C function
I-Feel

Indoor unit model			HKEDS 262 ZA	HKEDS 352 ZA
Outdoor unit model			HCNDS 262 ZA	HCNDS 352 ZA
Type			DC-Inverter heat pump	
Control (supplied)			Remote control	
Wi-Fi module			Integrated	
Nominal data				
Nominal capacity (T=+35°C)	Cooling	kW	2.70 (0.60~4.00)	3.50 (0.65~4.10)
Nominal absorbed power (T=+35°C)		kW	0.72 (0.10~1.20)	0.87 (0.13~1.55)
Nominal energy efficiency coefficient		EER ¹	3.75	4.02
Nominal capacity (T=+7°C)	Heating	kW	3.30 (0.80~4.20)	4.20 (0.93~4.20)
Nominal absorbed power (T=+7°C)		kW	0.80 (0.20~1.20)	1.06 (0.23~1.30)
Nominal energy performance coefficient		COP ¹	4.13	3.96
Seasonal data				
Theoretical load (Pdesignc)	Cooling	kW	2.70	3.50
Seasonal energy efficiency index		SEER ²	8.70	8.70
Seasonal energy efficiency class		626/2011 ³	A+++	A+++
Annual energy consumption		kWh/a	109	141
Theoretical load (Pdesignh) @ -10°C	Heating (average weather conditions)	kW	2.30	2.80
Seasonal performance coefficient		SCOP ²	4.70	4.70
Seasonal energy efficiency (ηs)		%	185	185
Seasonal energy efficiency class		626/2011 ³	A++	A++
Annual energy consumption		kWh/a	686	845
Electrical data				
Power supply	Outdoor unit	Ph-V-Hz	1Ph - 220/240V - 50Hz	
Power cable		Type	3 x 2.5 mm ²	
Wiring between I.U. and O.U.		no.	5	5
Nominal absorbed electric current	Cooling	A	3.30 (0.60~5.30)	4.20 (0.60~5.80)
	Heating	A	3.90 (1.00~5.30)	4.80 (1.00~6.30)
Max current		A	9.00	9.00
Max absorbed power		kW	1.60	1.50
Refrigerant circuit data				
Refrigerant ⁴		Type (GWP)	R32 (675)	
Q.ty of refrigerant pre-charge		Kg	0.55	0.60
Tons of CO2 equivalent		t	0.371	0.405
Liquid/gas refrigerant pipe diameter		mm (inches)	6.35(1/4") / 9.52(3/8")	6.35(1/4") / 9.52(3/8")
Max split length		m	20	20
Max difference in height I.U./O.U.		m	10	10
Split length without additional charge		m	5	5
Additional charge		g/m	20	20
Indoor unit specifications				
Dimensions	LxDxH	mm	768x201x299	827x201x299
Net weight		Kg	8	8.5
Sound power level	Hi	dB(A)	54	56
Sound pressure level	S/H/M/L/Silence	dB(A)	41/37/34/32/23	43/39/36/34/24
Treated air volume (S/H/M/L/Silence)	Cooling	m ³ /h	650/580/550/500/330	650/580/550/500/330
	Heating	m ³ /h	700/630/600/550/550	700/630/600/550/550
Special functions			UVC steriliser	
Outdoor unit specifications				
Dimensions	LxDxH	mm	708x258x530	708x258x530
Net weight		Kg	22.5	24.5
Sound power level		dB(A)	61	62
Sound pressure level		dB(A)	48	49
Treated air volume		m ³ /h	1800	2300
Operating limits (outdoor temperature)	Cooling	°C	15~53	
	Heating	°C	-25~30	

1. Value measured according to the harmonised standard EN14511. 2. EU Regulation No. 206/2012 - - Value measured according to the harmonised standard EN14825. 3. EU Delegated Regulation No. 626/2011 on the new energy consumption labelling of air conditioners. 4. Refrigerant leakage contributes to climate change. When released into the atmosphere, refrigerants with a lower global warming potential (GWP) contribute less to global warming than those with a higher GWP. This appliance contains a refrigerant with a GWP of 675. Therefore, if 1 kg of this refrigerant were released into the atmosphere, the impact on global warming would be 675 times higher than 1 kg of CO₂, over a period of 100 years. Under no circumstances should the user attempt to intervene on the refrigerant circuit or disassemble the product. In case of need, always contact qualified personnel.

COMPACT CASSETTE 60x60



COMPACT MONOSPLIT CASSETTE

Cassette air conditioning units are designed for commercial and residential applications. Ideal for large open spaces or irregularly shaped environments, they fit comfortably and discreetly into any environment with a false ceiling.

OPERATION

-15~**52**°C
in cooling

-15~24°**C**
in heating

PERFORMANCE

MODEL	SEER	SCOP
3.52 kW	6.20	4.00
5.28 kW	6.20	4.10

HTFDM 350-530 ZAL



Remote control included



-15-52° C in cooling
-15-24° C in heating

8-way panel
Condensation drain pump included

Provision for external
air renewal inlet

Indoor unit model			HTFDM 350 ZAL	HTFDM 530 ZAL
Outdoor unit model			HCKDS 350 ZA	HCKDS 530 ZA
Type			DC-Inverter heat pump	
Control (supplied)			Remote control	
Nominal data				
Nominal capacity (T=+35°C)	Cooling	kW	3.52 (1.35~4.40)	5.28 (1.53~5.60)
Nominal absorbed power (T=+35°C)		kW	1.03 (0.26~1.60)	1.55 (0.47~2.30)
Nominal energy efficiency coefficient		EER ¹	3.41	3.41
Nominal capacity (T=+7°C)	Heating	kW	3.81 (1.24~5.30)	5.60 (1.40~6.20)
Nominal absorbed power (T=+7°C)		kW	1.02 (0.19~1.51)	1.51 (0.46~2.25)
Nominal energy performance coefficient		COP ¹	3.73	3.71
Seasonal data				
Theoretical load (Pdesignc)	Cooling	kW	3.50	5.40
Seasonal energy efficiency index		SEER ²	6.20	6.20
Seasonal energy efficiency class		626/2011 ³	A++	A++
Annual energy consumption		kWh/a	198	305
Theoretical load (Pdesignh) @ -10°C	Heating (average weather conditions)	kW	2.70	4.50
Seasonal performance coefficient		SCOP ²	4.00	4.10
Seasonal energy efficiency (ηs)		%	157	161
Seasonal energy efficiency class		626/2011 ³	A+	A+
Annual energy consumption		kWh/a	926	1525
Electrical data				
Power supply	Outdoor unit	Ph-V-Hz	1Ph - 220/240V - 50Hz	
Power cable		Type	3 x 2.5 mm ²	3 x 4.0 mm ²
Wiring between I.U. and O.U.		no.	4	4
Nominal absorbed electric current	Cooling	A	4.50 (1.10~7.00)	6.70 (2.00~10.00)
	Heating	A	4.40 (0.80~6.60)	6.60 (2.00~9.80)
Max current		A	9.00	12.00
Max absorbed power		kW	1.70	2.40
Refrigerant circuit data				
Refrigerant ⁴		Type (GWP)	R32 (675)	
Q.ty of refrigerant pre-charge		Kg	0.78	1.03
Tons of CO2 equivalent		t	0.527	0.695
Liquid/gas refrigerant pipe diameter		mm (inches)	6.35(1/4") / 12.74(1/2")	6.35(1/4") / 12.74(1/2")
Max split length		m	25	30
Max difference in height I.U./O.U.		m	10	20
Split length without additional charge		m	5	5
Additional charge		g/m	30	30
Indoor unit specifications				
Dimensions	LxDxH	mm	570x570x260	570x570x260
Net weight		Kg	15.5	15.5
Sound power level	Erp test	dB(A)	52	56
Sound pressure level	Hi/Mi/Lo	dB(A)	42/38/35	44/41/38
Treated air volume	Hi/Mi/Lo	m ³ /h	700/620/530	760/650/580
Outdoor unit specifications				
Dimensions	LxDxH	mm	709x280x536	785x300x555
Net weight		Kg	23	29
Sound power level	Erp test	dB(A)	64	65
Sound pressure level		dB(A)	54	55
Treated air volume	Max	m ³ /h	2000	2600
Operating limits (outdoor temperature)	Cooling	°C	-15~-52	
	Heating	°C	-15~-24	
Accessories				
Decorative panel			HTFPD 260 ZAL	
Dimensions	LxDxH	mm	650x650x55	
Net weight		Kg	2.2	
Optional parts				
Wired control			WCD-05	

1. Value measured according to the harmonised standard EN14511. 2. EU Regulation No. 206/2012 - Value measured according to the harmonised standard EN14825. 3. EU Delegated Regulation No. 626/2011 on the new energy consumption labelling of air conditioners. 4. Refrigerant leakage contributes to climate change. When released into the atmosphere, refrigerants with a lower global warming potential (GWP) contribute less to global warming than those with a higher GWP. This appliance contains a refrigerant with a GWP of 675. Therefore, if 1 kg of this refrigerant were released into the atmosphere, the impact on global warming would be 675 times higher than 1 kg of CO₂, over a period of 100 years. Under no circumstances should the user attempt to intervene on the refrigerant circuit or disassemble the product. In case of need, always contact qualified personnel.

CASSETTE

84x84



CASSETTE MONOSPLIT AIR CONDITIONER

The 8-way ceiling cassette combines exceptional features with sophisticated design. Offering high seasonal efficiency and advanced control options, this range is extremely flexible and uses the low GWP R32 refrigerant.

OPERATION

-15~52°C
in cooling

-15~24°C
in heating

PERFORMANCE

MODEL	SEER	SCOP
7.03 kW	6.10	4.00

HTBDS 710 ZA



Remote control included



-15~52°C in cooling
-15~24°C in heating

8-way panel
Condensation drain pump included

Provision for external
air renewal inlet

Indoor unit model			HTBDS 710 ZA
Outdoor unit model			HCKDS 710 ZA
Type			DC-Inverter heat pump
Control (supplied)			Remote control
Nominal data			
Nominal capacity (T=+35°C)	Cooling	kW	7.03 (2.16~8.20)
Nominal absorbed power (T=+35°C)		kW	2.10 (0.67~3.30)
Nominal energy efficiency coefficient		EER ¹	3.35
Nominal capacity (T=+7°C)	Heating	kW	7.91 (1.98~9.30)
Nominal absorbed power (T=+7°C)		kW	2.13 (0.65~3.30)
Nominal energy performance coefficient		COP ¹	3.71
Seasonal data			
Theoretical load (Pdesignc)	Cooling	kW	7.00
Seasonal energy efficiency index		SEER ²	6.10
Seasonal energy efficiency class		626/2011 ³	A++
Annual energy consumption		kWh/a	397
Theoretical load (Pdesignh) @ -10°C	Heating (average weather conditions)	kW	6.00
Seasonal performance coefficient		SCOP ²	4.00
Seasonal energy efficiency (ηs)		%	157
Seasonal energy efficiency class		626/2011 ³	A+
Annual energy consumption		kWh/a	2052
Electrical data			
Power supply	Outdoor unit	Ph-V-Hz	1Ph - 220/240V - 50Hz
Power cable		Type	3 x 4.10 mm ²
Wiring between I.U. and O.U.		no.	4
Nominal absorbed electric current	Cooling	A	9.10 (2.90~14.40)
	Heating	A	9.30 (2.80~14.40)
Max current		A	16.00
Max absorbed power		kW	3.65
Refrigerant circuit data			
Refrigerant ⁴		Type (GWP)	R32 (675)
Q.ty of refrigerant pre-charge		Kg	1.45
Tons of CO2 equivalent		t	0.979
Liquid/gas refrigerant pipe diameter		mm (inches)	9.52(3/8") / 15.88(5/8")
Max split length		m	50
Max difference in height I.U./O.U.		m	25
Split length without additional charge		m	5
Additional charge		g/m	50
Indoor unit specifications			
Dimensions	LxDxH	mm	840x840x246
Net weight		Kg	26
Sound power level	Erp test	dB(A)	58.5
Sound pressure level	Hi/Mi/Lo	dB(A)	46.5/45/43
Treated air volume	Hi/Mi/Lo	m ³ /h	1500/1350/1200
Outdoor unit specifications			
Dimensions	LxDxH	mm	900x350x700
Net weight		Kg	43
Sound power level	Erp test	dB(A)	70
Sound pressure level		dB(A)	58
Treated air volume	Max	m ³ /h	4200
Operating limits (outdoor temperature)	Cooling	°C	-15~-52
	Heating	°C	-15~-24
Accessories			
Decorative panel			HTBPD 710 ZA
Dimensions	LxDxH	mm	950x950x55
Net weight		Kg	5.3
Optional parts			
Wired control			WCD-05

1. Value measured according to the harmonised standard EN14511. 2. EU Regulation No. 206/2012 - Value measured according to the harmonised standard EN14825. 3. EU Delegated Regulation No. 626/2011 on the new energy consumption labelling of air conditioners. 4. Refrigerant leakage contributes to climate change. When released into the atmosphere, refrigerants with a lower global warming potential (GWP) contribute less to global warming than those with a higher GWP. This appliance contains a refrigerant with a GWP of 675. Therefore, if 1 kg of this refrigerant were released into the atmosphere, the impact on global warming would be 675 times higher than 1 kg of CO2, over a period of 100 years. Under no circumstances should the user attempt to intervene on the refrigerant circuit or disassemble the product. In case of need, always contact qualified personnel.

DUCTED MEDIUM STATIC PRESSURE



DUCTED MONOSPLIT AIR CONDITIONER

Hokkaido ducted units combine premium features with discreet design for easy installation and maintenance. Our ducted air conditioning units are suitable for residential and commercial applications.

OPERATION

-15~52°C
in cooling

-15~24°C
in heating

PERFORMANCE

MODEL	SEER	SCOP
3.52 kW	6.40	4.00
5.28 kW	6.10	4.00
7.03 kW	6.10	4.00

RESIDENTIAL & COMMERCIAL R32

HRDDM 350-530 ZAL | HRDDS 710 ZA



-15~52°C in cooling
-15~24°C in heating

Condensation drain pump included
Wired control included

10~160 Pa adjustable static pressure

Indoor unit model		HRDDM 350 ZAL		HRDDM 530 ZAL		HRDDS 710 ZA	
Outdoor unit model		HCKDS 350 ZA		HCKDS 530 ZA		HCKDS 710 ZA	
Type				DC-Inverter heat pump			
Control (supplied)				Wired control			
Nominal data							
Nominal capacity (T=+35°C)	Cooling	kW	3.52 (1.35~14.40)	5.28 (1.53~5.60)	7.03 (2.16~8.20)		
Nominal absorbed power (T=+35°C)		kW	1.03 (0.26~1.60)	1.55 (0.47~2.30)	2.17 (0.67~3.30)		
Nominal energy efficiency coefficient		EER ¹	3.41	3.40	3.24		
Nominal capacity (T=+7°C)	Heating	kW	3.81 (1.24~5.30)	5.60 (1.40~6.20)	7.91 (1.98~9.30)		
Nominal absorbed power (T=+7°C)		kW	1.02 (0.19~1.51)	1.49 (0.46~2.25)	2.13 (0.65~3.30)		
Nominal energy performance coefficient		COP ¹	3.73	3.76	3.71		
Seasonal data							
Theoretical load (Pdesignc)	Cooling	kW	3.50	5.40	7.10		
Seasonal energy efficiency index		SEER ²	6.40	6.10	6.10		
Seasonal energy efficiency class		626/2011 ³	A++	A++	A++		
Annual energy consumption		kWh/a	193	307	406		
Theoretical load (Pdesignh) @ -10°C	Heating (average weather conditions)	kW	2.70	4.40	5.40		
Seasonal performance coefficient		SCOP ²	4.00	4.00	4.00		
Seasonal energy efficiency (ηs)		%	157	157	157		
Seasonal energy efficiency class		626/2011 ³	A+	A+	A+		
Annual energy consumption		kWh/a	931	1520	1884		
Electrical data							
Power supply	Outdoor unit	Ph-V-Hz	1Ph - 220/240V - 50Hz				
Power cable		Type	3 x 2.5 mm ²	3 x 2.5 mm ²	3 x 4.0 mm ²		
Wiring between I.U. and O.U.		no.	4	4	4		
Nominal absorbed electric current	Cooling	A	4.50 (1.10~7.00)	6.70 (2.00~10.00)	9.40 (2.90~14.30)		
	Heating	A	4.40 (0.80~6.60)	6.50 (2.00~9.80)	9.30 (2.80~14.40)		
Max current		A	9.00	12.00	16.00		
Max absorbed power		kW	1.70	2.40	3.65		
Refrigerant circuit data							
Refrigerant ⁴		Type (GWP)	R32 (675)				
Q.ty of refrigerant pre-charge		Kg	0.78	1.03	1.45		
Tons of CO2 equivalent		t	0.527	0.695	0.979		
Liquid/gas refrigerant pipe diameter		mm (inches)	6.35(1/4") / 12.74(1/2")	6.35(1/4") / 12.74(1/2")	9.52(3/8") / 15.88(5/8")		
Max split length		m	25	30	50		
Max difference in height I.U./O.U.		m	10	20	25		
Split length without additional charge		m	5	5	5		
Additional charge		g/m	30	30	50		
Indoor unit specifications							
Dimensions	LxDxH	mm	700x700x245	700x700x245	1000x700x245		
Net weight		Kg	21	22	32		
Sound power level	Erp test	dB(A)	55	59	55		
Sound pressure level	Hi/Mi/Lo	dB(A)	37/34/32	44/41/37	43/41/39		
Treated air volume	Hi/Mi/Lo	m ³ /h	720/600/500	900/750/630	1400/1190/980		
Fan's static pressure	Std/Max	Pa	25/160	25/160	25/160		
Outdoor unit specifications							
Dimensions	LxDxH	mm	709x280x536	785x300x555	900x350x700		
Net weight		Kg	23	29	43		
Sound power level	Erp test	dB(A)	64	65	70		
Sound pressure level		dB(A)	54	55	58		
Treated air volume	Max	m ³ /h	2000	2600	4200		
Operating limits (outdoor temperature)	Cooling	°C	-15~52				
	Heating	°C	-15~24				

1. Value measured according to the harmonised standard EN14511. 2. EU Regulation No. 206/2012 - Value measured according to the harmonised standard EN14825. 3. EU Delegated Regulation No. 626/2011 on the new energy consumption labelling of air conditioners. 4. Refrigerant leakage contributes to climate change. When released into the atmosphere, refrigerants with a lower global warming potential (GWP) contribute less to global warming than those with a higher GWP. This appliance contains a refrigerant with a GWP of 675. Therefore, if 1 kg of this refrigerant were released into the atmosphere, the impact on global warming would be 675 times higher than 1 kg of CO₂, over a period of 100 years. Under no circumstances should the user attempt to intervene on the refrigerant circuit or disassemble the product. In case of need, always contact qualified personnel.

CONSOLE



CONSOLE MONOSPLIT AIR CONDITIONER

The new Hokkaido console indoor unit has been designed to ensure maximum functionality combined with a pleasant and modern appearance. Thanks to the diversified air flows, these indoor units allow you to obtain a pleasant temperature inside the room.

OPERATION

-15~52°C
in cooling

-15~24°C
in heating

PERFORMANCE

MODEL	SEER	SCOP
3.50 kW	7.50	4.10
4.70 kW	6.80	4.10

RESIDENTIAL & COMMERCIAL R32

HFIDM 350-530 ZAL



App "AC Freedom"

Remote control included



-15-52°C in cooling
-15-24°C in heating

DDouble air flow, upper and lower
Double installation option, floor-mounted or wall-mounted

Indoor unit model		HFIDM 350 ZAL		HFIDM 530 ZAL	
Outdoor unit model		HCKDS 350 ZA		HCKDS 530 ZA	
Type		DC-Inverter heat pump			
Control (supplied)		Remote control			
Wi-Fi module		Integrated			
Nominal data					
Nominal capacity (T=+35°C)	Cooling	kW	3.50 (1.35~4.40)	4.70 (1.53~5.60)	
Nominal absorbed power (T=+35°C)		kW	1.03 (0.26~1.60)	1.45 (0.47~2.30)	
Nominal energy efficiency coefficient		EER ¹	3.40	3.24	
Nominal capacity (T=+7°C)	Heating	kW	3.50 (1.24~5.30)	5.00 (1.40~6.20)	
Nominal absorbed power (T=+7°C)		kW	0.94 (0.19~1.51)	1.34 (0.46~2.25)	
Nominal energy performance coefficient		COP ¹	3.72	3.73	
Seasonal data					
Theoretical load (Pdesignc)	Cooling	kW	3.50	5.00	
Seasonal energy efficiency index		SEER ¹	7.50	6.80	
Seasonal energy efficiency class		626/2011 ³	A++	A++	
Annual energy consumption		kWh/a	162	257	
Theoretical load (Pdesignh) @ -10°C	Heating (average weather conditions)	kW	2.70	3.70	
Seasonal performance coefficient		SCOP ²	4.10	4.10	
Seasonal energy efficiency (ηs)		%	161	161	
Seasonal energy efficiency class		626/2011 ³	A+	A+	
Annual energy consumption		kWh/a	923	1261	
Electrical data					
Power supply	Outdoor unit	Ph-V-Hz	1Ph - 220/240V - 50Hz		
Power cable		Type	3 x 2.5 mm ²	3 x 2.5 mm ²	
Wiring between I.U. and O.U.		no.	4	4	
Nominal absorbed electric current	Cooling	A	4.50 (1.10~7.00)	6.30 (2.00~10.00)	
	Heating	A	4.10 (0.80~6.60)	5.80 (2.00~9.80)	
Max current		A	9.00	12.00	
Max absorbed power		kW	1.70	2.40	
Refrigerant circuit data					
Refrigerant ⁴		Type (GWP)	R32 (675)		
Q.ty of refrigerant pre-charge		Kg	0.78	1.03	
Tons of CO ₂ equivalent		t	0.527	0.695	
Liquid/gas refrigerant pipe diameter		mm (inches)	6.35(1/4") / 12.74(1/2")	6.35(1/4") / 12.74(1/2")	
Max split length		m	25	30	
Max difference in height I.U./O.U.		m	10	20	
Split length without additional charge		m	5	5	
Additional charge		g/m	30	30	
Indoor unit specifications					
Dimensions	LxDxH	mm	700x225x600	700x225x600	
Net weight		Kg	15	15	
Sound power level	Hi	dB(A)	52	56	
Sound pressure level	Hi/Mi/Lo	dB(A)	42/39/36	44/40/37	
Treated air volume	Hi/Mi/Lo	m ³ /h	600/530/430	650/550/450	
Outdoor unit specifications					
Dimensions	LxDxH	mm	709x280x536	785x300x555	
Net weight		Kg	23	29	
Sound power level		dB(A)	64	65	
Sound pressure level		dB(A)	54	55	
Treated air volume	Max	m ³ /h	2000	2600	
Operating limits (outdoor temperature)	Cooling	°C	-15~52		
	Heating	°C	-15~24		
Optional parts					
Wired control			WCD-05		

1. Value measured according to the harmonised standard EN14511. 2. EU Regulation No. 206/2012 - - Value measured according to the harmonised standard EN14825. 3. EU Delegated Regulation No. 626/2011 on the new energy consumption labelling of air conditioners. 4. Refrigerant leakage contributes to climate change. When released into the atmosphere, refrigerants with a lower global warming potential (GWP) contribute less to global warming than those with a higher GWP. This appliance contains a refrigerant with a GWP of 675. Therefore, if 1kg of this refrigerant were released into the atmosphere, the impact on global warming would be 675 times higher than 1kg of CO₂, over a period of 100 years. Under no circumstances should the user attempt to intervene on the refrigerant circuit or disassemble the product. In case of need, always contact qualified personnel.

FLOOR/CEILING



TWO TYPES OF INSTALLATION

New design and ease of control, elegant and slim profile.

Large air distribution grille with aerodynamic flaps to ensure fast operation and reduce noise levels.

OPERATION

-15~**52**°C
in cooling

-15~24°**C**
in heating

PERFORMANCE

MODEL	SEER	SCOP
5.30 kW	6.20	4.20
7.03 kW	6.20	4.00

RESIDENTIAL & COMMERCIAL R32

HSFDM 530 ZAL | HSFDS 710 ZA



Remote control included



-15~52°C in cooling
-15~24°C in heating

Double installation possibility,
floor or ceiling

The increased air flow allows for better air conditioning even in the largest rooms

Indoor unit model			HSFDM 530 ZAL	HSFDS 710 ZA
Outdoor unit model			HCKDS 530 ZA	HCKDS 710 ZA
Type			DC-Inverter heat pump	
Control (supplied)			Remote control	
Nominal data				
Nominal capacity (T=+35°C)	Cooling	kW	5.30 (1.60~6.00)	7.03 (2.16~8.20)
Nominal absorbed power (T=+35°C)		kW	1.55 (0.48~2.30)	2.15 (0.67~3.30)
Nominal energy efficiency coefficient		EER ¹	3.42	3.27
Nominal capacity (T=+7°C)	Heating	kW	5.70 (1.40~7.20)	7.62 (1.98~9.30)
Nominal absorbed power (T=+7°C)		kW	1.52 (0.47~2.40)	2.05 (0.65~3.30)
Nominal energy performance coefficient		COP ¹	3.75	3.72
Seasonal data				
Theoretical load (Pdesignc)	Cooling	kW	5.40	7.20
Seasonal energy efficiency index		SEER ²	6.20	6.20
Seasonal energy efficiency class		626/2011 ³	A++	A++
Annual energy consumption		kWh/a	303	404
Theoretical load (Pdesignh) @ -10°C	Heating (average weather conditions)	kW	4.50	5.50
Seasonal performance coefficient		SCOP ²	4.20	4.00
Seasonal energy efficiency (ηs)		%	165	157
Seasonal energy efficiency class		626/2011 ³	A+	A+
Annual energy consumption		kWh/a	1500	1897
Electrical data				
Power supply	Outdoor unit	Ph-V-Hz	1Ph - 220/240V - 50Hz	
Power cable		Type	3 x 2.5 mm ²	3 x 4 mm ²
Wiring between I.U. and O.U.		no.	4	4
Nominal absorbed electric current	Cooling	A	6.70 (2.10~10.00)	9.30 (2.90~14.40)
	Heating	A	6.60 (2.00~10.40)	8.90 (2.80~14.40)
Max current		A	12.00	16.00
Max absorbed power		kW	2.40	3.65
Refrigerant circuit data				
Refrigerant ⁴		Type (GWP)	R32 (675)	
Q.ty of refrigerant pre-charge		Kg	1.03	1.45
Tons of CO2 equivalent		t	0.695	0.979
Liquid/gas refrigerant pipe diameter		mm (inches)	6.35(1/4") / 12.74(1/2")	9.52(3/8") / 15.88(5/8")
Max split length		m	30	50
Max difference in height I.U./O.U.		m	20	25
Split length without additional charge		m	5	5
Additional charge		g/m	30	50
Indoor unit specifications				
Dimensions	LxDxH	mm	1000x690x235	1280x690x235
Net weight		Kg	28	34
Sound power level	Erp test	dB(A)	52	54
Sound pressure level	Hi/Mi/Lo	dB(A)	40/35/33	42/38/35
Treated air volume	Hi/Mi/Lo	m ³ /h	900/720/600	1230/1020/840
Outdoor unit specifications				
Dimensions	LxDxH	mm	785x300x555	900x350x700
Net weight		Kg	29	43
Sound power level	Erp test	Erp test	65	70
Sound pressure level		dB(A)	55	58
Treated air volume	Max	m ³ /h	2600	4200
Operating limits (outdoor temperature)	Cooling	°C	-15~52	
	Heating	°C	-15~24	
Optional parts				
Wired control			WCD-05	

1. Value measured according to the harmonised standard EN14511. 2. EU Regulation No. 206/2012 - - Value measured according to the harmonised standard EN14825. 3. EU Delegated Regulation No. 626/2011 on the new energy consumption labelling of air conditioners. 4. Refrigerant leakage contributes to climate change. When released into the atmosphere, refrigerants with a lower global warming potential (GWP) contribute less to global warming than those with a higher GWP. This appliance contains a refrigerant with a GWP of 675. Therefore, if 1 kg of this refrigerant were released into the atmosphere, the impact on global warming would be 675 times higher than 1 kg of CO₂, over a period of 100 years. Under no circumstances should the user attempt to intervene on the refrigerant circuit or disassemble the product. In case of need, always contact qualified personnel.

R32 MULTISPLIT

Outdoor unit	EER*	COP*	SEER	SCOP
HCKDM 400 Z2	3.31	3.91	6.20	4.10
HCKDM 530 Z2	3.23	3.78	6.10	4.10
HCKDM 600 Z3	3.23	3.71	6.10	4.20
HCKDM 800 Z3	3.23	3.71	6.20	4.10

* The values reported may vary depending on the combinations chosen. For more information, refer to the technical manuals.

OPERATION RANGE

-10° C / 52° C **-15° C / 24° C**
 in cooling in heating

INSTALLATION FLEXIBILITY

Long split lengths.

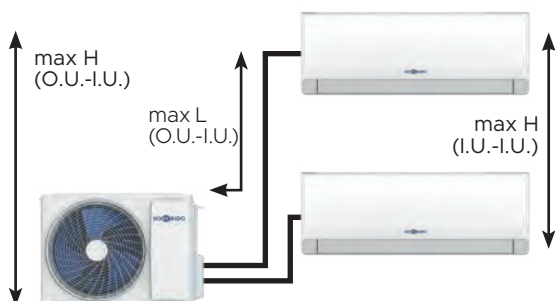

HIGH COMPACTNESS

High compactness and easy installation.

HCKDM 400-530 Z2

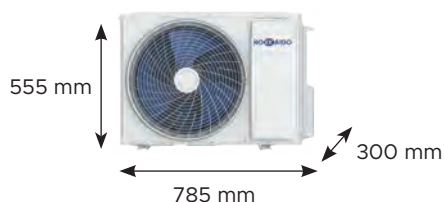

HCKDM 600-800 Z3



HCKDM 400-530 Z2

- L TOTAL PIPING = 40 m
- L MAX O.U.-I.U. = 25 m
- H MAX O.U.-I.U. = 15 m
- H MAX I.U.-I.U. = 10 m

HCKDM 600-800 Z3

- L TOTAL PIPING = 60 m
- L MAX O.U.-I.U. = 30 m
- H MAX O.U.-I.U. = 15 m
- H MAX I.U.-I.U. = 10 m

R32 MULTISPLIT

	kW	4.10	5.30	6.20	7.90
Max number of connectable indoor units		2	2	3	3
					
		HCKDM 400 Z2	HCKDM 530 Z2	HCKDM 600 Z3	HCKDM 800 Z3
	HKEDM 203 ZL	✓	✓	✓	✓
	HKEDM 263 ZL	✓	✓	✓	✓
	HKEDM 353 ZL	✓	✓	✓	✓
	HKEDM 533 ZL	✓	✓	✓	✓

Yields and consumption are measured under the following test conditions:
 heating O.T. 7° C DB, 6° C WB - I.T. 20° C DB; cooling O.T. 35° C DB, 24° C WB - I.T. 27° C DB, 19° C WB (ISO T1).



R32 MULTISPLIT



HCKDM 400 Z2
HCKDM 530 Z2

HCKDM 600 Z3
HCKDM 800 Z3

A++/A+ (6.15~7.91 kW) | Energy efficiency class in cooling/heating

Extended operating range in heating down to an outdoor temperature of -15° C, and in cooling up to an **outdoor temperature of +52° C**

Maximum flexibility and ease of installation guaranteed by a long length of the refrigerant pipes

Check the maximum gas concentration limits, particularly in residential applications, as required by Standard EN 378:2016.

Model			HCKDM 400 Z2	HCKDM 530 Z2	HCKDM 600 Z3	HCKDM 800 Z3
Type			Outdoor unit DC-Inverter heat pump			
Connectable indoor units (min - max)		no.	1-2	1-2	1-3	1-3
Nominal data						
Nominal capacity (T=+35°C)	Cooling	kW	4.10 (1.80~4.51)	5.30 (2.00~5.83)	6.20 (2.20~6.71)	7.90 (2.30~8.69)
Nominal absorbed power (T=+35°C)		kW	1.24 (0.20~2.10)	1.64 (0.28~2.30)	1.92 (0.35~2.80)	2.44 (0.56~3.40)
Nominal energy efficiency coefficient		EER ¹	3.31	3.23	3.23	3.23
Nominal capacity (T=+7°C)	Heating	kW	4.50 (2.05~5.28)	5.60 (2.21~6.16)	6.60 (2.39~7.26)	8.20 (2.45~9.02)
Nominal absorbed power (T=+7°C)		kW	1.15 (0.20~2.10)	1.48 (0.28~2.30)	1.78 (0.35~2.80)	2.21 (0.56~3.40)
Nominal energy performance coefficient		COP ¹	3.91	3.78	3.71	3.71
Seasonal data						
Theoretical load (Pdesignc)	Cooling	kW	4.10	5.30	6.20	7.90
Seasonal energy efficiency index		SEER ²	6.20	6.10	6.10	6.20
Seasonal energy efficiency class		626/2011 ³	A++	A++	A++	A++
Annual energy consumption		kWh/a	233	301	354	453
Theoretical load (Pdesignh) @ -10°C	Heating (average weather conditions)	kW	3.70	4.80	5.70	5.60
Seasonal performance coefficient		SCOP ²	4.10	4.10	4.20	4.10
Seasonal energy efficiency (ηs)		%	161	161	165	161
Seasonal energy efficiency class		626/2011 ³	A+	A+	A+	A+
Annual energy consumption		kWh/a	1256	1639	1900	1875
Electrical data						
Power supply	Ph-V-Hz		1-220~240V-50HZ			
Power cable	Type		3 x 2.5 mm ²	3 x 2.5 mm ²	3 x 4 mm ²	3 x 4 mm ²
Fili collegamento tra ogni I.U. and O.U.	no.		4	4	4	4
Nominal absorbed electric current	Cooling	A	5.40	7.10	8.40	10.60
	Heating	A	5.00	6.40	7.70	9.60
Max current	A		12.00	13.00	14.00	16.50
Max absorbed power	kW		2.76	3.00	3.00	3.80
Refrigerant circuit data						
Refrigerant ⁴	Type (GWP)		R32 (675)			
Q.ty of refrigerant pre-charge	Kg		1.00	1.03	1.15	1.45
Tons of CO2 equivalent	t		0.675	0.695	0.776	0.979
Liquid/gas refrigerant pipe diameter	mm (inches)		2 x 6.35(1/4")	2 x 6.35(1/4")	3 x 6.35(1/4")	3 x 6.35(1/4")
			2 x 9.52(3/8")	2 x 9.52(3/8")	3 x 9.52(3/8")	3 x 9.52(3/8")
Total split length	m		40	40	60	60
Max length of a single refrigerant line	m		25	25	30	30
Max difference in height I.U./O.U.	m		15	15	15	15
Max difference in height between I.U.	m		10	10	10	10
Split length without additional charge	m		15	15	22.5	22.5
Additional charge	g/m		25	25	25	25
Product specifications						
Dimensions	LxDxH	mm	785x300x555	785x300x555	900x350x700	900x350x700
Net weight	Kg		30	30	41.5	44.5
Sound power level	dB(A)		65	65	66	67
Sound pressure level	dB(A)		53	54	56	57
Treated air volume	m ³ /h		2600	2600	4100	4100
Operating limits (outdoor temperature)	Cooling	°C	-10~52			
	Heating	°C	-15~24			

1. Value measured according to the harmonised standard EN14511. 2. EU Regulation No. 206/2012 - - Value measured according to the harmonised standard EN14825. The energy efficiency values refer to the following combinations: **HCKDM 400 Z2 + 2 x HKEDM 263 ZL - HCKD M530 Z2 + 2 x HKEDM 263 ZL - HCKDM 600 Z3 + 3 x HKEDM 263 ZL - HCKDM 800 Z3 + 3 x HKEDM 263 ZL**. 3. EU Delegated Regulation No. 626/2011 on the new energy consumption labelling of air conditioners. 4. Refrigerant leakage contributes to climate change. When released into the atmosphere, refrigerants with a lower global warming potential (GWP) contribute less to global warming than those with a higher GWP. This appliance contains a refrigerant with a GWP of 675. Therefore, if 1 kg of this refrigerant were released into the atmosphere, the impact on global warming would be 675 times higher than 1 kg of CO2, over a period of 100 years. Under no circumstances should the user attempt to intervene on the refrigerant circuit or disassemble the product. In case of need, always contact qualified personnel.

LUMINA MULTI

Wall HKEDM 203-263-353-533 ZL



App Smartlife



Wi-Fi included



-10-52°C in cooling
-15-24°C in heating

Auto restart
8°C function

I-Feel

Model			HKEDM 203 ZL	HKEDM 263 ZL	HKEDM 353 ZL	HKEDM 533 ZL
Type	Wall type indoor unit					
Control (supplied)	Remote control					
Wi-Fi module	Integrated					
Nominal data						
Nominal capacity	Cooling	kW	2.10	2.60	3.50	5.30
Nominal capacity	Heating	kW	2.40	2.90	3.80	5.40
Electrical data						
Power supply	Outdoor unit	Ph-V-Hz	1Ph - 220/240V - 50Hz			
Wiring between I.U. and O.U.		no.	4	4	4	4
Refrigerant circuit data						
Liquid/gas refrigerant pipe diameter		mm (inches)	6.35(1/4") / 9.52(3/8")	6.35(1/4") / 9.52(3/8")	6.35(1/4") / 9.52(3/8")	6.35(1/4") / 12.74(1/2")
Product specifications						
Dimensions	LxDxH	mm	768x201x299	768x201x299	768x201x299	997x222x312
Net weight		Kg	7	7	7.5	11
Sound power level	(Turbo/Hi/Mi/Lo/Silence)	dB(A)	57/50/46/42/33	57/50/46/42/33	57/50/46/42/33	60/52/47/43/35
Sound pressure level	(Turbo/Hi/Mi/Lo/Silence)	dB(A)	43/41/38/35/26	43/41/38/35/26	43/41/38/35/26	47/44/39/36/28
Treated air volume	(Turbo/Hi/Mi/Lo/Silence)	m³/h	650/570/520/470/350	650/570/520/470/350	650/570/520/470/350	950/830/750/660/480



**EFFECTIVE AGAINST
VIRUSES AND
BACTERIA**



**SMART MANAGEMENT
WITH WIFI
APP SMARTLIFE**



**HEAT EXCHANGER
TREATED WITH ANTI-
CORROSION COATING**



**PCB OF THE OUTDOOR
UNIT COOLED BY
REFRIGERANT**

52°C ^{TOP}

External temperature range in cooling mode
up to 52°C, unique on the market

Design and installation flexibility on all power sizes, with split data corresponding to the highest on the market.

Cooling operating range, which guarantees fresh air in summer up to an external temperature of 52°C.

The values shown are the result of an internal comparative analysis with the main competitors in the relevant market segment. Values updated in September 2025 based on data in the 2025 public catalogues.

Ask your sales representative for more information.

KEY

^{TOP} Top feature, the best data on the market

★ Silver feature, one of the best figures on the market

COMBINATIONS



COMBINATIONS

HKCDM 400 Z2 cooling

Connected indoor units		Combination		Nominal cooling capacity (kW)		Total cooling performance (kW)	Power absorbed (kW)	EER (W/W)	Pdesignc	SEER	Annual consumption (kWh)	Energy class
		Unit A	Unit B	Unit A	Unit B	std	std	std				
1 unit	20	20	-	2.05	-	2.05	0.63	3.23	-	-	-	-
	26	26	-	2.55	-	2.55	0.79	3.23	-	-	-	-
	35	35	-	3.50	-	3.50	1.08	3.23	-	-	-	-
	53	53	-	4.10	-	4.10	1.27	3.23	-	-	-	-
2 units	20+20	20	20	2.05	2.05	4.10	1.24	3.31	4.1	6.1	234	A++
	20+26	20	26	1.79	2.31	4.10	1.24	3.31	4.1	6.1	232	A++
	20+35	20	35	1.51	2.59	4.10	1.24	3.31	4.1	6.1	232	A++
	26+26	26	26	2.05	2.05	4.10	1.24	3.31	4.1	6.1	232	A++
	26+35	26	35	1.76	2.34	4.10	1.24	3.31	4.1	6.1	232	A++

Energy class = EU Delegated Regulation No. 626/2011 on the new labelling indicating the energy consumption of air conditioners.
SEER = EU Regulation No. 206/2012 -- Value measured according to the harmonized standard EN14825. EER = Value measured according to the harmonized standard EN14511

HKCDM 400 Z2 heating

Connected indoor units		Combination		Nominal heating capacity (kW)		Total heating output (kW)	Power absorbed (kW)	COP (W/W)	Pdesignc	SCOP	Annual consumption (kWh)	Energy class
		Unit A	Unit B	Unit A	Unit B	std	std	std				
1 unit	20	20	-	2.15	-	2.15	0.54	4.01	-	-	-	-
	26	26	-	2.65	-	2.65	0.66	4.01	-	-	-	-
	35	35	-	3.50	-	3.50	0.88	4.00	-	-	-	-
	53	53	-	4.80	-	4.80	1.20	4.00	-	-	-	-
2 units	20+20	20	20	2.40	2.40	4.80	1.15	4.17	3.5	4.0	1217	A+
	20+26	20	26	2.10	2.70	4.80	1.15	4.17	3.6	4.0	1243	A+
	20+35	20	35	1.77	3.03	4.80	1.15	4.17	3.6	4.0	1243	A+
	26+26	26	26	2.40	2.40	4.80	1.15	4.17	3.6	4.0	1243	A+
	26+35	26	35	2.06	2.74	4.80	1.15	4.17	3.6	4.0	1243	A+

Energy class = EU Delegated Regulation No. 626/2011 on the new labelling indicating the energy consumption of air conditioners.
SCOP = EU Regulation No. 206/2012 -- Value measured according to the harmonized standard EN14825. COP = Value measured according to the harmonized standard EN14511.

HKCDM 530 Z2 cooling

Connected indoor units		Combination		Nominal cooling capacity (kW)		Total cooling performance (kW)	Power absorbed (kW)	EER (W/W)	Pdesignc	SEER	Annual consumption (kWh)	Energy class
		Unit A	Unit B	Unit A	Unit B	std	std	std				
1 unit	20	20	-	2.05	-	2.05	0.64	3.20	-	-	-	-
	26	26	-	2.55	-	2.55	0.80	3.19	-	-	-	-
	35	35	-	3.50	-	3.50	1.07	3.27	-	-	-	-
	53	53	-	5.30	-	5.30	1.65	3.21	-	-	-	-
2 units	20+20	20	20	2.05	2.05	4.10	1.24	3.30	5.00	6.1	259	A++
	20+26	20	26	2.06	2.64	4.70	1.46	3.23	5.10	6.1	259	A++
	20+35	20	35	1.95	3.35	5.30	1.69	3.14	5.30	6.1	259	A++
	26+26	26	26	2.65	2.65	5.30	1.75	3.03	5.30	6.1	300	A++
	26+35	26	35	2.27	3.03	5.30	1.83	3.01	5.30	6.1	259	A++
	35+35	35	35	2.65	2.65	5.30	1.83	3.01	5.30	6.1	259	A++

Energy class = EU Delegated Regulation No. 626/2011 on the new labelling indicating the energy consumption of air conditioners.
SEER = EU Regulation No. 206/2012 -- Value measured according to the harmonized standard EN14825. EER = Value measured according to the harmonized standard EN14511

HKCDM 530 Z2 heating

Connected indoor units		Combination		Nominal heating capacity (kW)		Total heating output (kW)	Power absorbed (kW)	COP (W/W)	Pdesignc	SCOP	Annual consumption (kWh)	Energy class
		Unit A	Unit B	Unit A	Unit B	std	std	std				
1 unit	20	20	-	2.15	-	2.15	0.57	3.72	-	-	-	-
	26	26	-	2.65	-	2.65	0.71	3.73	-	-	-	-
	35	35	-	3.50	-	3.50	0.94	3.73	-	-	-	-
	53	53	-	5.40	-	5.40	1.45	3.71	-	-	-	-
2 units	20+20	20	20	2.50	2.50	5.00	1.34	3.72	4.65	4.00	1590	A+
	20+26	20	26	2.32	2.98	5.30	1.43	3.70	4.80	4.00	1656	A+
	20+35	20	35	2.03	3.47	5.50	1.51	3.64	4.80	4.00	1656	A+
	26+26	26	26	2.80	2.80	5.60	1.50	3.73	4.80	4.00	1654	A+
	26+35	26	35	2.40	3.20	5.60	1.51	3.72	4.80	4.00	1656	A+
	35+35	35	35	2.80	2.80	5.60	1.51	3.72	4.80	4.00	1656	A+

Energy class = EU Delegated Regulation No. 626/2011 on the new labelling indicating the energy consumption of air conditioners.
SCOP = EU Regulation No. 206/2012 -- Value measured according to the harmonized standard EN14825. COP = Value measured according to the harmonized standard EN14511.

COMBINATIONS

HCKDM 600 Z3 cooling

Connected indoor units		Combination			Nominal cooling capacity (kW)			Total cooling performance (kW)	Power absorbed (kW)	EER (W/W)	Pdesignc	SEER	Annual consumption (kWh)	Energy class
		Unit A	Unit B	Unit C	Unit A	Unit B	Unit C	std	std	std				
1 unit	53	53	-	-	5.30	-	-	5.30	1.65	3.21	-	-	-	-
2 units	20+20	20	20	-	2.05	2.05	-	4.10	1.27	3.23	4.0	5.6	265	A+
	20+26	20	26	-	2.01	2.59	-	4.60	1.42	3.23	4.8	5.6	299	A+
	20+35	20	35	-	1.99	3.41	-	5.40	1.67	3.23	5.2	5.6	341	A+
	20+53	20	53	-	1.76	4.54	-	6.30	1.94	3.24	6.2	5.6	397	A+
	26+26	26	26	-	2.60	2.60	-	5.20	1.61	3.23	5.3	5.6	341	A+
	26+35	26	35	-	2.57	3.43	-	6.00	1.86	3.23	6.0	5.6	387	A+
	26+53	26	53	-	2.10	4.20	-	6.30	1.94	3.24	6.2	5.6	397	A+
	35+35	35	35	-	3.10	3.10	-	6.20	1.93	3.21	6.2	5.6	387	A+
35+53	35	53	-	2.46	3.74	-	6.20	1.93	3.21	6.2	5.6	387	A+	
3 units	20+20+20	20	20	20	2.07	2.07	2.07	6.20	1.92	3.23	6.2	6.1	355	A++
	20+20+26	20	20	26	1.92	1.92	2.46	6.30	1.94	3.24	6.3	6.1	362	A++
	20+20+35	20	20	35	1.70	1.70	2.90	6.30	1.94	3.24	6.3	6.1	362	A++
	20+26+26	20	26	26	1.76	2.27	2.27	6.30	1.94	3.24	6.3	6.1	362	A++
	20+26+35	20	26	35	1.58	2.03	2.70	6.30	1.94	3.24	6.3	6.1	362	A++
	20+35+35	20	35	35	1.42	2.44	2.44	6.30	1.94	3.24	6.3	6.1	362	A++
	26+26+26	26	26	26	2.10	2.10	2.10	6.30	1.94	3.24	6.3	6.1	362	A++
	26+26+35	26	26	35	1.89	1.89	2.52	6.30	1.94	3.24	6.3	6.1	362	A++

Energy class = EU Delegated Regulation No. 626/2011 on the new labelling indicating the energy consumption of air conditioners.
SEER = EU Regulation No. 206/2012 - - Value measured according to the harmonized standard EN14825. EER = Value measured according to the harmonized standard EN14511

HCKDM 600 Z3 heating

Connected indoor units		Combination			Nominal cooling capacity (kW)			Total heating output (kW)	Power absorbed (kW)	COP (W/W)	Pdesignc	SCOP	Annual consumption (kWh)	Energy class
		Unit A	Unit B	Unit C	Unit A	Unit B	Unit C	std	std	std				
1 unit	53	53	-	-	5.40	-	-	5.40	1.59	3.40	-	-	-	-
2 units	20+20	20	20	-	2.50	2.50	-	5.00	1.39	3.59	4.3	3.8	1485	A
	20+26	20	26	-	2.45	3.15	-	5.60	1.56	3.59	4.5	3.8	1655	A
	20+35	20	35	-	2.14	3.66	-	5.80	1.59	3.64	5.0	3.8	1770	A
	20+53	20	53	-	1.76	4.54	-	6.30	1.75	3.60	5.4	3.9	1832	A
	26+26	26	26	-	3.15	3.15	-	6.30	1.73	3.64	5.0	3.8	1832	A
	26+35	26	35	-	2.70	3.60	-	6.30	1.73	3.64	5.4	3.8	1832	A
	26+53	26	53	-	2.10	4.20	-	6.30	1.75	3.60	5.4	4.0	1832	A+
	35+35	35	35	-	3.15	3.15	-	6.30	1.73	3.64	5.4	4.0	1832	A+
35+53	35	53	-	2.50	3.80	-	6.30	1.73	3.64	5.4	4.0	1832	A+	
3 units	20+20+20	20	20	20	2.20	2.20	2.20	6.60	1.78	3.71	5.7	4.0	1977	A+
	20+20+26	20	20	26	2.02	2.02	2.56	6.60	1.79	3.71	5.6	4.0	1925	A+
	20+20+35	20	20	35	1.78	1.78	3.04	6.60	1.82	3.71	5.7	4.0	1930	A+
	20+26+26	20	26	26	1.84	2.38	2.38	6.60	1.82	3.71	5.7	4.0	1930	A+
	20+26+35	20	26	35	1.65	2.12	2.83	6.60	1.82	3.71	5.7	4.0	1930	A+
	20+35+35	20	35	35	1.49	2.55	2.55	6.60	1.82	3.71	5.7	4.0	1930	A+
	26+26+26	26	26	26	2.20	2.20	2.20	6.60	1.82	3.71	5.7	4.0	1930	A+
	26+26+35	26	26	35	1.98	1.98	2.64	6.60	1.82	3.71	5.7	4.0	1930	A+

Energy class = EU Delegated Regulation No. 626/2011 on the new labelling indicating the energy consumption of air conditioners.
SCOP = EU Regulation No. 206/2012 - - Value measured according to the harmonized standard EN14825. COP = Value measured according to the harmonized standard EN14511.

COMBINATIONS

HCKDM 800 Z3 cooling

Connected indoor units		Combination			Nominal cooling capacity (kW)			Total cooling performance (kW)	Power absorbed (kW)	EER (W/W)	Pdesignc	SEER	Annual consumption (kWh)	Energy class
		Unit A	Unit B	Unit C	Unit A	Unit B	Unit C	std	std	std				
1 unit	53	53	—	—	5.30	—	—	5.30	1.65	3.23	—	—	—	—
2 units	20+20	20	20	—	2.05	2.05	—	4.10	1.27	3.23	4.1	6.1	234	A++
	20+26	20	26	—	2.01	2.59	—	4.60	1.42	3.23	4.6	6.1	260	A++
	20+35	20	35	—	1.99	3.41	—	5.40	1.67	3.23	5.4	6.1	294	A++
	20+53	20	53	—	1.79	4.61	—	6.40	1.98	3.23	6.4	6.1	363	A++
	26+26	26	26	—	2.65	2.65	—	5.30	1.64	3.23	5.3	6.1	294	A++
	26+35	26	35	—	2.70	3.60	—	6.30	1.95	3.23	6.3	6.1	335	A++
	26+53	26	53	—	2.25	4.55	—	6.80	2.11	3.23	6.8	6.1	378	A++
	35+35	35	35	—	3.20	3.20	—	6.40	1.98	3.23	6.4	6.1	351	A++
3 units	20+20+20	20	20	20	2.40	2.40	2.40	7.20	2.24	3.21	7.3	6.1	391	A++
	20+20+26	20	20	26	2.25	2.25	2.90	7.40	2.31	3.21	7.4	6.1	397	A++
	20+20+35	20	20	35	2.13	2.13	3.64	7.90	2.46	3.21	7.9	6.1	438	A++
	20+20+53	20	20	53	1.73	1.73	4.44	7.90	2.45	3.23	7.9	6.1	438	A++
	20+26+26	20	26	26	2.22	2.84	2.84	7.90	2.46	3.21	7.9	6.1	425	A++
	20+26+35	20	26	35	1.98	2.55	3.37	7.90	2.46	3.21	7.9	6.1	438	A++
	20+26+53	20	26	53	1.63	2.10	4.17	7.90	2.45	3.23	7.9	6.1	438	A++
	20+35+35	20	35	35	1.78	3.06	3.06	7.90	2.45	3.23	7.9	6.1	438	A++
	26+26+26	26	26	26	2.63	2.63	2.63	7.90	2.46	3.21	7.9	6.1	447	A++
	26+26+35	26	26	35	2.37	2.37	3.16	7.90	2.46	3.23	7.9	6.1	438	A++
	26+26+53	26	26	53	1.98	1.98	3.95	7.90	2.46	3.23	7.9	6.1	438	A++
	26+35+35	26	35	35	2.16	2.87	2.87	7.90	2.46	3.23	7.9	6.1	438	A++
	26+35+53	26	35	53	1.82	2.43	3.65	7.90	2.46	3.23	7.9	6.1	438	A++
	35+35+35	35	35	35	2.63	2.63	2.63	7.90	2.46	3.23	7.9	6.1	438	A++

Energy class = EU Delegated Regulation No. 626/2011 on the new labelling indicating the energy consumption of air conditioners.
SEER = EU Regulation No. 206/2012 -- Value measured according to the harmonized standard EN14825. EER = Value measured according to the harmonized standard EN14511

HCKDM 800 Z3 heating

Connected indoor units		Combination			Nominal cooling capacity (kW)			Total heating output (kW)	Power absorbed (kW)	COP (W/W)	Pdesignc	SCOP	Annual consumption (kWh)	Energy class
		Unit A	Unit B	Unit C	Unit A	Unit B	Unit C	std	std	std				
1 unit	53	53	—	—	5.40	—	—	5.40	1.54	3.50	—	—	—	—
2 units	20+20	20	20	—	2.50	2.50	—	5.00	1.41	3.55	4.9	3.8	1873	A
	20+26	20	26	—	2.45	3.15	—	5.60	1.58	3.55	5.8	3.8	2106	A
	20+35	20	35	—	2.17	3.73	—	5.90	1.64	3.61	6.0	3.8	2106	A
	20+53	20	53	—	1.96	5.04	—	7.00	1.94	3.61	6.0	3.8	2106	A
	26+26	26	26	—	2.95	2.95	—	5.90	1.64	3.61	6.0	3.8	2106	A
	26+35	26	35	—	2.70	3.60	—	6.30	1.75	3.61	6.0	3.8	2106	A
	26+53	26	53	—	2.45	4.55	—	7.00	1.94	3.61	6.0	3.8	2292	A
	35+35	35	35	—	3.25	3.25	—	6.50	1.75	3.61	6.0	3.8	2292	A
3 units	20+20+20	20	20	20	2.27	2.27	2.27	6.80	1.88	3.61	6.9	4.0	2373	A+
	20+20+26	20	20	26	2.13	2.13	2.74	7.00	1.94	3.61	6.9	4.0	2373	A+
	20+20+35	20	20	35	2.11	2.11	3.62	7.85	2.17	3.61	6.9	4.0	2373	A+
	20+20+53	20	20	53	1.82	1.82	4.66	8.30	2.29	3.63	6.9	4.0	2373	A+
	20+26+26	20	26	26	2.19	2.83	2.83	7.85	2.17	3.61	6.9	4.0	2373	A+
	20+26+35	20	26	35	2.06	2.63	3.51	8.20	2.27	3.61	6.9	4.0	2373	A+
	20+26+53	20	26	53	1.72	2.19	4.39	8.30	2.29	3.62	6.9	4.0	2373	A+
	20+35+35	20	35	35	1.88	3.21	3.21	8.30	2.30	3.61	6.9	4.0	2373	A+
	26+26+26	26	26	26	2.73	2.73	2.73	8.20	2.20	3.73	6.9	4.0	2393	A+
	26+26+35	26	26	35	2.49	2.49	3.32	8.30	2.29	3.61	6.9	4.0	2373	A+
	26+26+53	26	26	53	2.08	2.08	4.15	8.30	2.27	3.63	6.9	4.0	2373	A+
	26+35+35	26	35	35	2.26	3.02	3.02	8.30	2.27	3.63	6.9	4.0	2373	A+
	26+35+53	26	35	53	1.92	2.55	3.83	8.30	2.27	3.63	6.9	4.0	2373	A+
	35+35+35	35	35	35	2.77	2.77	2.77	8.30	2.27	3.63	6.9	4.0	2373	A+

Energy class = EU Delegated Regulation No. 626/2011 on the new labelling indicating the energy consumption of air conditioners.
SCOP = EU Regulation No. 206/2012 -- Value measured according to the harmonized standard EN14825. COP = Value measured according to the harmonized standard EN14511.

PROJECT VRF R410A FULL DC INVERTER

PROJECT VRF R410A FULL DC INVERTER, EFFICIENCY & EASY INSTALLATION

Strengthened by its constant commitment to technological research and its long experience in the air conditioning market in Italy and Europe, Hokkaido presents the **PROJECT VRF R410A**.

Efficiency, reliability and **application flexibility** are the quality answers that the XRV Systems offer for the different application needs of installers, designers and end customers.

51 Line up

52 **XRV PLUS MINI**

53 **SERIES P INDOOR UNITS**

XRV MULTI SYSTEM DESIGN & SAVINGS

THE ADVANTAGES OF A HOKKAIDO SYSTEM

Hokkaido VRFs offer energy efficiency, their installation guarantees a rapid economic return on investment.

The high efficiency of Hokkaido VRF systems is achieved through the use of Inverter compressors. The systems are customizable to meet the specifications of any project, making them particularly attractive for large areas, commercial and industrial activities.

FULL DC INVERTER TECHNOLOGY FOR OUTDOOR UNITS

Full DC Inverter technology has always characterized the Hokkaido proposal in the VRF heat pump system market. The outdoor units are all equipped with a DC Inverter compressor and a fan with a DC Inverter motor: high results in terms of energy efficiency, reduction of operating costs and reduction of CO2 emissions..

THIS IS WHAT MAKES HOKKAIDO'S PROPOSAL "FULL".

Energy saving & comfort

The Full DC Inverter technology (DC Inverter compressor and DC Inverter motor for the fan/s) applied to the external units of the highlighted XRV systems, ensures high EER and COP values not only at full load, but above all at partial loads, guaranteeing energy savings and high comfort within a wide external temperature range.

HIGH-EFFICIENCY DC INVERTER COMPRESSOR

Thanks to the use of the DC Inverter compressor, which allows the quantity of compressed refrigerant to be varied quickly and continuously, the outdoor units of the XRV systems are characterized by:

- rapid commissioning of the system;
- fast response to changes in the user's cooling or heating demand;
- reduction of on/off cycles.

The result is an efficient system, with high reliability and durability over time.

DC FAN MOTOR

The use of the DC Inverter motor for the fan ensures energy savings during partial loads, as it regulates the fan speed, and contributes to making the unit quieter. The design of the fan and exhaust grille guarantees an increase in air flow resulting in a low noise level.



DC Inverter compressor



DC Inverter fan motor

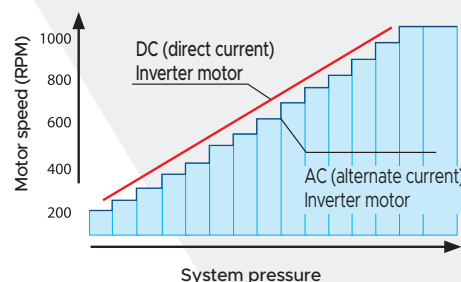

XRV MULTI SYSTEM

Heat pump outdoor units

3-PHASE XRV PLUS MINI

7HP
HCYU 2006 XRV





8HP
HCYU 2246 XRV

9HP
HCYU 2606 XRV

10HP
HCYU 2806 XRV



Series P indoor units

		kW 2.20 2.80 3.60 4.50 5.60 7.10 9.00 11.20 12.50 14.00											
Cassette	8-way compact 60x60  HTFU XRV-P	✓	✓	✓	✓								
	8-way 84x84  HTBU XRV-P					✓	✓	✓	✓				✓
Ducted	medium static pressure  HUCU XRV-P		✓	✓	✓	✓	✓	✓	✓				
Wall	 HKEU XRV-P	✓	✓	✓	✓	✓	✓						
Floor	floor/ceiling  HSFU XRV-P			✓	✓	✓	✓	✓	✓	✓			✓

Performance and consumption are based on the following test conditions:
cooling: O.T. 35° C DB, 24° C WB - I.T. 27° C DB, 19° C WB (ISO 5151 Standard); heating: O.T. 7° C DB, 6° C WB - I.T. 20° C DB, 15° C WB (ISO 5151 Standard).

XRV PLUS MINI

Heat pump



HCYU 2006 XRV HCYU 2606 XRV
HCYU 2246 XRV HCYU 2806 XRV

All units are equipped with high efficiency Full DC Inverter compressors.

Fan with DC Inverter motor:

- wider fan speed adjustment;
- noise reduction.

Up to 16 indoor units connected to one compact outdoor unit.

Self-diagnosis function for main system problems.

Splitting and height difference lengths

Model	HCYU 2006 XRV	HCYU 2246 XRV	HCYU 2606 XRV	HCYU 2806 XRV
Max. distance between O.U. and the farthest I.U.	110 m	110 m	110 m	110 m
Max. distance from the first branch pipe to the farthest I.U.	40 m	40 m	40 m	40 m
Max. height difference between upper O.U. and I.U.	50 m	50 m	50 m	50 m
Max. height difference between lower O.U. and I.U.	40 m	40 m	40 m	40 m
Max. height difference between I.U.	15 m	15 m	15 m	15 m
Maximum length of the pipes	150 m	150 m	150 m	150 m

Wide operating range:

- cooling -5° C ~ +48° C;
- heating -20° C ~ +24° C.

Auto-addressing of indoor units.

Model			HCYU 2006 XRV	HCYU 2246 XRV	HCYU 2606 XRV	HCYU 2806 XRV
Power		HP	7	8	9	10
Rated capacity ¹	Cooling	kW	20.00	22.40	26.00	28.00
		kW	5.28	6.77	10.04	12.02
		EER	3.79	3.31	2.59	2.33
Rated capacity ²	Heating	kW	20.00	22.40	26.00	28.00
		kW	4.43	5.42	6.86	7.55
		COP	4.51	4.13	3.79	3.71
Seasonal data						
Seasonal performance coefficient	Heating	SCOP	4.04	4.34	4.47	4.50
		Seasonal energy efficiency (η _s)	%	158.60	170.60	175.80
Electrical data						
Power supply		Ph-V-Hz	3-380~415V50Hz			
Maximum current		A	19.00	19.00	20.50	21.00
Refrigerant circuit						
Refrigerant ³		Type (GWP)	R410A (2088)			
Quantity refrigerant pre-load ⁴ (tons of CO ₂ equivalent)		Kg (t)	6.5 (13.572)	6.5 (13.572)	6.5 (13.572)	6.5 (13.572)
Compressor		no. / type	1 / Rotary DC Inverter			
Diameter of refrigerant pipings	Liquid	mm (inch)	9.53 (3/8")		9.53 (3/8")	
	Gas	mm (inch)	19.1 (3/4")		22.2 (7/8")	
Product specifications						
Dimensions		LxHxD	mm 1120x1558x528			
Net weight		Kg	143		144	
Sound power level		max dB(A)	78		78	
Sound pressure level at 1 m		max dB(A)	58		59	
Treated air volume		max m ³ /h	9000		10000	
Operating range (outdoor temperature)	Cooling	°C	-5~48			
	Heating	°C	-20~24			
Connectable indoor units (min - max)		no.	1 - 11	1 - 13	1 - 15	1 - 16
Capacity of connectable indoor units		%	50 - 130			

1. Cooling capacity tested in accordance with ISO 5151 Standard. Outdoor temperature 35°C DB, 24°C WB and indoor temperature 27°C DB, 19° WB
 2. Heating capacity tested in accordance with ISO 5151 Standard. Outdoor temperature 7°C DB, 6°C WB and indoor temperature 20°C DB, 15°C WB
 3. Refrigerant leakage contributes to climate change. When released into the atmosphere, refrigerants with a lower global warming potential (GWP) contribute less to global warming than those with a higher GWP. This appliance contains a refrigerant with a GWP of 2088. If 1 kg of this refrigerant fluid were released into the atmosphere, therefore, the impact on global warming would be 2088 times higher than 1 kg of CO₂, over a period of 100 years. Under no circumstances should the user try to intervene on the refrigerant circuit or disassemble the product. Always contact qualified personnel if necessary.
 4. For the calculation of the additional refrigerant charge, refer to the labels placed inside and outside the unit.

HTFU XRV-P

8-way compact cassette 60x60



Ultra-compact design
22 dB(A) (2.20-2.80 kW)
high silence

Condensate drainage pump with
the possibility of raising the drain
up to 500 mm from the lower level

360° air diffusion
**The controller must be purchased
as an accessory**

Model			HTFU 225 XRV-P	HTFU 285 XRV-P	HTFU 365 XRV-P	HTFU 455 XRV-P
Rated capacity	Cooling	kW	2.20	2.80	3.60	4.50
	Heating	kW	2.40	3.20	4.00	5.00
Electrical data						
Power supply		Ph-V-Hz	1-220~240V-50Hz			
Absorbed power		W	35	35	40	50
Product specifications						
Dimensions		LxHxD	630x260x570			
Net weight		Kg	18			19.2
Sound power level ¹	Max~Min	dB(A)	51~38			56~43
	Sound pressure level at 1.4 m ¹	Max~Min	dB(A)	35~22		41~28
Treated air volume ¹	Max~Min	m ³ /h	576~405			604~400
	Diameter of the connections	Liquid/Gas	mm (inch)	6.35 (1/4") / 12.7 (1/2")		
Condensate		mm	32			
Accessories						
Decorative panel			TFP 155 XRV-P			
Panel dimensions		LxHxD	647x50x647			
Net weight		Kg	2.5			
Remote control			DHIR-5-6-XRV-K-P			
Wired control			DHW-5-6-XRV-P			

1. Values relating to the Max and Min speeds of 7 levels that can be set by remote control.

HTBU XRV-P

8-way cassette 84x84



Optimized fan design to
attenuate air resistance and
reduce sound level

**Predisposition for the
connection of a duct
for the introduction of
external air**

Condensate drainage
pump with the possibility of
raising the drain up to 750
mm from the lower level

**The controller must
be purchased as an
accessory**

Model			HTBU 565 XRV-P	HTBU 715 XRV-P	HTBU 905 XRV-P	HTBU 1125 XRV-P	HTBU 1405 XRV-P
Rated capacity	Cooling	kW	5.60	7.10	9.00	11.20	14.00
	Heating	kW	6.30	8.00	10.00	12.50	16.00
Electrical data							
Power supply		Ph-V-Hz	1-220~240V-50Hz				
Absorbed power		W	31	46	75		94
Product specifications							
Dimensions		LxHxD	840x230x840		840x300x840		
Net weight		Kg	23.2		28.4		30.7
Sound power level ¹	Max~Min	dB(A)	56~47	58~47	61~50		64~52
	Sound pressure level at 1.4 m ¹	Max~Min	dB(A)	43~34	45~34	47~36	
Treated air volume ¹	Max~Min	m ³ /h	1029~704	1200~748	1596~1034		1727~1224
	Diameter of the connections	Liquid/Gas	mm (inch)	9.52 (3/8") / 15.9 (5/8")			
Condensate		mm	32				
Accessories							
Decorative panel			TBP 712 IHXR				
Panel dimensions		LxHxD	950x70x950				
Net weight		Kg	5.8				
Remote control			DHIR-5-6-XRV-K-P				
Wired control			DHW-5-6-XRV-P				

1. Values relating to the Max and Min speeds of 7 levels that can be set by remote control.

HUCU XRV-P

Ducted medium static pressure



Only 210 mm high

(2.80~7.10 kW) compact design perfect for use in hotels

Available static pressure:

50 Pa (2.80~7.10 kW);
100 Pa (9.00~11.20 kW)

Air intake from bottom or rear

Condensate drain pump included with possibility of raising the discharge up 750 mm from the lower height

Compatible with systems



The control must be purchased as an accessory

Model			HUCU 285 XRV-P	HUCU 365 XRV-P	HUCU 455 XRV-P
Rated capacity	Cooling	kW	2.80	3.60	4.50
	Heating	kW	3.20	4.00	5.00
Electrical data					
Power supply		Ph-V-Hz	1-220~240V-50Hz		
Absorbed power		W	40	45	92
Product specifications					
Dimensions	LxHxD	mm	780x210x500		1000x210x500
Net weight		Kg	18		21.5
Sound power level ¹	Max~Min	dB(A)	50~41	51~43	54~43
Sound pressure level at 1.4 m ¹	Max~Min	dB(A)	32~23	33~25	36~25
Treated air volume ¹	Max~Min	m ³ /h	520~300	580~370	800~400
Fan static pressure	Std/Max	Pa	10/50		
Diameter of connections	Liquid/Gas	mm (inch)	6.35 (1/4") / 12.7 (1/2")		
	Condensate	mm	25		
Accessories					
Remote control			DHIR-5-6-XRV-K-P		
Wired control			DHW-5-6-XRV-P		

1. Values relating to the Max and Min speeds of 7 levels that can be set by remote control.

Model			HUCU 565 XRV-P	HUCU 715 XRV-P	HUCU 905 XRV-P	HUCU 1125 XRV-P
Rated capacity	Cooling	kW	5.60	7.10	9.00	11.20
	Heating	kW	6.30	8.00	10.00	12.50
Electrical data						
Power supply		Ph-V-Hz	1-220~240V-50Hz			
Absorbed power		W	92	98	120	200
Product specifications						
Dimensions	LxHxD	mm	1000x210x500	1220x210x500	1230x270x775	
Net weight		Kg	21.5	27.5	37	
Sound power level ¹	Max~Min	dB(A)	54~46	55~46	55~46	57~51
Sound pressure level at 1.4 m ¹	Max~Min	dB(A)	36~28	37~28	37~28	39~33
Treated air volume ¹	Max~Min	m ³ /h	830~560	1000~680	1260~780	1500~1080
Fan static pressure	Std/Max	Pa	10/50		20/100	
Diameter of connections	Liquid/Gas	mm (inch)	9.52 (3/8") / 15.9 (5/8")			
	Condensate	mm	25			
Accessories						
Remote control			DHIR-5-6-XRV-K-P			
Wired control			DHW-5-6-XRV-P			

1. Values relating to the Max and Min speeds of 7 levels that can be set by remote control.

HKEU XRV-P

Wall



Compact design
Washable standard filter

203 mm deep (2.20-2.80 kW)
extremely compact

29 dB(A) (2.20-2.80 kW)
extremely silent

The control must be purchased as an accessory

Model			HKEU 225 XRV-P	HKEU 285 XRV-P	HKEU 365 XRV-P	HKEU 455 XRV-P	HKEU 565 XRV-P	HKEU 715 XRV-P	
Rated capacity	Cooling	kW	2.20	2.80	3.60	4.50	5.60	7.10	
	Heating	kW	2.40	3.20	4.00	5.00	6.30	8.00	
Electrical data									
Power supply		Ph-V-Hz	1-220~240V-50Hz						
Absorbed power		W	28		30	40	45	55	
Product specifications									
Dimensions		LxHxD	835x280x203			990x315x223		1194x343x262	
Net weight		Kg	8.4	9.5	11.4	12.8		17	
Sound power level ¹		Max~Min	dB(A) 46~44		48~45	50~46		53~49	
Sound pressure level at 1.4 m ¹		Max~Min	dB(A) 31~29		33~30	35~31		38~34	
Treated air volume ¹		Max~Min	m ³ /h 422~356		417~316	656~488		594~424	
Diameter of connections		Liquid/Gas	mm (inch) 6.35 (1/4") / 12.7 (1/2")			9.52 (3/8") / 15.9 (5/8")		11.9 (5/8") / 15.9 (5/8")	
		Condensate	mm 16						
Accessories									
Remote control			DHIR-5-6-XRV-K-P						
Wired control			DHW-5-6-XRV-P						

1. Values relating to the Max and Min speeds of 7 levels that can be set by remote control.

HSFU XRV-P

Floor/ceiling



Auto Swing function | Optimises the distribution of air flow in the room

Built-in electronic expansion valve
Easy installation with unit mounted to the floor or to the ceiling

The control must be purchased as an accessory

Model			HSFU 365 XRV-P	HSFU 455 XRV-P	HSFU 565 XRV-P	HSFU 715 XRV-P	HSFU 905 XRV-P	HSFU 1125 XRV-P	HSFU 1405 XRV-P
Rated capacity	Cooling	kW	3.60	4.50	5.60	7.10	9.00	11.20	14.00
	Heating	kW	4.00	5.00	6.30	8.00	10.00	12.50	15.00
Electrical data									
Power supply		Ph-V-Hz	1-220~240V-50Hz						
Absorbed power		W	49	115			130	180	180
Product specifications									
Dimensions		LxHxD	990x660x203			1280x660x203		1670x680x244	
Net weight		Kg	27	28			35	48	
Sound power level ¹		Max~Min	dB(A) 53~49		56~51		58~53		60~55
Sound pressure level at 1.4 m ¹		Max~Min	dB(A) 40~36		43~38		45~40		47~42
Treated air volume ¹		Max~Min	m ³ /h 550~420		930~720		1280~1050		1890~1580
Diameter of connections		Liquid/Gas	mm (inch) 6.35 (1/4") / 12.7 (1/2")			9.52 (3/8") / 15.9 (5/8")		9.52 (3/8") / 15.9 (5/8")	
		Condensate	mm 16						
Accessories									
Remote control			DHIR-5-6-XRV-K-P						
Wired control			DHW-5-6-XRV-P						

1. Values relating to the Max and Min speeds of 7 levels that can be set by remote control.

HEATING





HEATING, THE RANGE THAT MEETS EVERY NEED

The careful process of product selection and system design is developed in Italy and then, thanks to continuous technological research, is implemented in an exclusive range, a point of reference on the hydronic pump market.

HEATING selects and collects excellent products for heating, air conditioning and DHW production in residential and commercial settings.

58 KŪKI MIZU MONOBLOC R32

Air-to-water heat pump

62 HOT WATER

Heat pump water heater

KŪKI MIZU

AIR-WATER HEAT PUMP MONOBLOC R32 FOR COOLING, HEATING AND DHW

- **6 capacities:**
6-9-12-18-22-30 kW
- Colour **Touch Screen Wired Control** included as standard

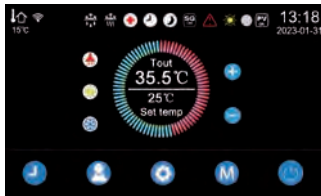

- Automatic management of the heating flow temperature via climate curve



SMART GRID

Reading the trend of the electricity grid, energy savings guaranteed



Control via **Wi-Fi app**



KŪKI MIZU MONOBLOC R32



A+++

Energy class in heating mode with **35°C** flow water temperature.

A++

Energy class in heating mode with **55°C** flow water temperature.



EFFICIENCY AND PERFORMANCE ALL YEAR ROUND

Heating performance guaranteed down to -25°C outdoor temperature.

The Kūki Mizu heat pump can be installed in any climate zone, even in those with the most severe conditions. In summer, cooling is provided up to 45°C outdoor temperature.

-25°/+45°C

Outdoor temperature in heating

-10°/+45°C

Outdoor temperature in cooling

-25°/+45°C

Outdoor temperature in DHW production

20~60°C

Water temperature in heating

7~25°C

Water temperature in cooling

KŪKI MIZU MONOBLOC R32



1-Phase 6.60-9.15-12.20 kW
HCWNBS 600-900-1200 Z

ENERGY CLASS

A+++

In heating mode with **35°C** flow water temperature.

ENERGY CLASS

A++

In heating mode with **55°C** flow water temperature.

Model				HCWNBS 600 Z	HCWNBS 900 Z	HCWNBS 1200 Z
Heating	Rated power	A7//W35	kW	6.60	9.15	12.20
	Power consumption			1.42	2.15	2.94
	Coefficient of performance			4.65	4.26	4.15
	Rated power	A7//W55	kW	5.33	7.75	10.24
	Power consumption			1.71	2.83	3.45
	Coefficient of performance			3.12	2.74	2.97
Cooling	Rated power	A35//W18	kW	6.25	8.99	11.00
	Power consumption			1.54	2.41	3.08
	Energy efficiency			4.06	3.73	3.57
	Rated power	A35//W7	kW	5.16	6.86	9.44
	Power consumption			1.88	2.58	3.48
	Energy efficiency			2.74	2.66	2.71
Seasonal heating data	Prated @ -10°C	35/55	kW	5.10/5.10	5.90/6.00	8.10/7.50
	Seasonal energy efficiency (ηs)			178.8/128.6	177.6/130.5	181.1/131.0
	Seasonal energy efficiency index			4.55/3.29	4.51/3.34	4.60/3.35
	Energy efficiency class			-	A+++/A+++	A+++/A+++
	Annual energy consumption			kWh/a	2296/3203	2684/3724
Operating limits	Outdoor air temperature	Heating	°C	-25~45		
		Cooling		10~45		
		DHW		-25~45		
	Delivery water temperature	Heating	°C	25~60		
		Cooling		7~25		
		DHW		25~60		
Refrigerant circuit data	Refrigerant ¹	type (GWP)		R32 (675)		
	Quantity (tons CO ₂)	kg (t)		1.40 (0.94)		2.10 (1.42)
	Control system	Electronic expansion valve				
	Compressor	type		Rotary - DC Inverter		
Hydraulic data	Heat exchanger	Type	Plate-welded, brazed Stainless Steel			
		Water flow rate	m ³ /h	1.1	1.5	1.9
		Pressure drops	kPa	22	40	50
	Circulation pump	Included				
	Water connections	Type	Threaded			
		Dimension	Inches	1" (DN25)		
Operating pressure Min/Max	bar		0.5/3.0			
Expansion vessel	Volume	L	5			
Electrical data	Power supply	Ph/V/Hz		1ph-230V-50Hz		
	Maximum current	A		12.00	15.00	17.00
	Power cable (recommended)	type		3x2.5 mm ²		
Product specifications	Fan	Type	q.ty	DC Inverter x 1		
		Air flow rate	m ³ /h	-	-	-
	Sound power level	dB(A)		60	63	64
	Sound pressure level	dB(A)		46	48	49
	Dimensions	LxDxH	mm	1115x415x900		
	Weight	Net	kg	80	82	125
Control (supplied)	Wired control					

The above data refers to the following standards: EN 14511:2018; EN 14825:2019; EN50564:2011; EN12102-1:2018; EN12102-2:2019; (EU)No:811:2013; (EU)No:813:2013; OJ 2014/C 207/02:2014.

1. Refrigerant leakage contributes to climate change. Refrigerants with a lower global warming potential (GWP) contribute less to global warming when released into the atmosphere than those with a higher GWP.

This appliance contains a refrigerant with a GWP of 675. Therefore, if 1 kg of this refrigerant were released into the atmosphere, the impact on global warming would be 675 times greater than 1 kg of CO₂, over a period of 100 years. Under no circumstances should the user attempt to intervene on the refrigerant circuit or disassemble the product. In case of need, always contact qualified personnel.

KŪKI MIZU MONOBLOC R32



3-Phase 19.10-23.00-30.00 kW
 HCWSBS 1800-2200-3000 Z

ENERGY CLASS

A+++

In heating mode with **35°C** flow water temperature.

ENERGY CLASS

A++

In heating mode with **55°C** flow water temperature.

Model				HCWSBS 1800 Z	HCWSBS 2200 Z	HCWSBS 3000 Z	
Heating	Rated power	A7//W35	kW	19.10	23.00	30.00	
	Power consumption			4.44	5.00	7.45	
	Coefficient of performance			4.30	4.60	3.96	
	Rated power	A7//W55	kW	14.73	18.31	27.50	
	Power consumption			4.70	5.87	10.00	
	Coefficient of performance			3.13	3.12	2.75	
Cooling	Rated power	A35//W18	kW	17.82	21.00	27.23	
	Power consumption			4.92	5.66	8.46	
	Energy efficiency			3.62	3.71	3.22	
	Rated power	A35//W7	kW	14.95	16.50	20.50	
	Power consumption			5.20	5.70	7.88	
	Energy efficiency			2.88	2.89	2.60	
Seasonal heating data	Prated @ -10°C	35/55	kW	11.30/10.50	12.00/12.00	15.80/15.10	
	Seasonal energy efficiency (ηs)			%	179.7/132.5	183.2/125.2	177.8/130.4
	Seasonal energy efficiency index			SCOP	4.57/3.39	4.66/3.21	4.52/3.35
	Energy efficiency class			-	A+++/A++	A+++/A++	A+++/A++
	Annual energy consumption			kWh/a	5102/6430	6820/8320	10081/12383
Operating limits	Outdoor air temperature	Heating	°C	-25~45			
		Cooling		10~45			
		DHW		-25~45			
	Delivery water temperature	Heating		25~60			
		Cooling		7~25			
		DHW		25~60		25~55	
Refrigerant circuit data	Refrigerant ¹	type (GWP)	R32 (675)				
	Quantity (tons CO2)	kg (t)	3.00 (2.03)		3.56 (2.40)		
	Control system	Electronic expansion valve					
	Compressor	type	Rotary - DC Inverter				
Hydraulic data	Heat exchanger	Type	Plate-welded, brazed Stainless Steel				
		Water flow rate	m³/h	3.1	4.0	5.16	
		Pressure drops	kPa	60	40	40	
	Circulation pump	Included					
	Water connections	Type	Threaded				
		Dimension	Inches	1-1/4" (DN32)			
Operating pressure Min/Max	bar		0.5/3.0				
Expansion vessel	Volume	L	5				
Electrical data	Power supply	Ph/V/Hz		3ph-400V-50Hz			
	Maximum current	A		9.40	12.00	22.28	
	Power cable (recommended)	type		5x2.5 mm²		5x4 mm²	
Product specifications	Fan	Type	DC Inverter x 2				
		Air flow rate	m³/h	-	-	-	
	Sound power level	dB(A)		67	73	70	
	Sound pressure level	dB(A)		52	58	55	
	Dimensions	LxDxH	mm		1115x415x1320		
	Weight	Net	kg		175	180	166
Control (supplied)	Wired control						

The above data refers to the following standards: EN 14511:2018; EN 14825:2019; EN50564:2011; EN12102-1:2018; EN12102-2:2019; (EU)No:811:2013; (EU)No:813:2013; OJ 2014/C 207/02:2014.

1. Refrigerant leakage contributes to climate change. Refrigerants with a lower global warming potential (GWP) contribute less to global warming when released into the atmosphere than those with a higher GWP.

This appliance contains a refrigerant with a GWP of 675. Therefore, if 1 kg of this refrigerant were released into the atmosphere, the impact on global warming would be 675 times greater than 1 kg of CO2, over a period of 100 years. Under no circumstances should the user attempt to intervene on the refrigerant circuit or disassemble the product. In case of need, always contact qualified personnel.

HEATING

HOT WATER

HWMB5 1080-1100 J

Heat pump water heater
monobloc 80 and 107 liters series "Ducted kitchen"



Monobloc heat pump water heater,
designed to be installed inside the kitchen
column unit

R290 | Refrigerant gas

65° C | Water temperature
with compressor only
Anti-legionella cycle
Stainless steel tank
Titanium Anode

Removable upper body with horizontal extraction,
to facilitate maintenance and installation
operations in narrow spaces
ErP Ready

PERFORMANCE

MODEL	RATED LOAD	ENERGY CLASS	COP According EN 16147
HWMB5 1080 J	80 L	A+	2.93
HWMB5 1100 J	107 L	A+	3.03

Model		HWMB5 1080 J	HWMB5 1100 J
Tank volume	L	80	107
Nominal thermal power ¹	W	1000	1000
Nominal power consumption ¹	W	210	210
Nominal COP ¹	W/W	4.76	4.76
Nominal DHW production capacity ¹	L/h	20.00	20.00
COPDHW ²	W/W	2.93	3.03
Test cycle profile ²	-	M	M
Hot water volume at 40°C ²	L	114	140
Energy efficiency (η wh) ³	%	123.1	128.6
Energy efficiency class ³	-	A+	A+
IP protection rating	-	IPX1	IPX1
Hot water temperature regulation range	°C	35~65	35~65
Maximum hot water temperature compressor only	°C	65	65
Electrical data	Power supply	Ph-V-Hz 1-220~240V-50Hz	
	Integrative electrical resistance	1500	1500
	Maximum current (including resistance)	A 8.30	8.30
Refrigerant circuit data	Refrigerant ⁴	Type (GWP) R290 (0.02)	R290 (0.02)
	Quantity	g 140	140
	Compressor	type Rotary ON/OFF	
Hydraulic data	Tank material	Stainless Steel 304	
	DHW connections	inches G1/2" (DN15)	G1/2" (DN15)
	Solar coil connections	inches -	-
	Maximum operating pressure	bar 10	10
Air ducts	Air flow rate (with ducts)	m³/h 280	280
	Fan's static pressure	Pa 60	60
	Internal diameter	mm 125	125
	Maximum length	m 8	8
Product specifications	Working range (compressor only)	°C -5~+43	-5~+43
	Anode type	Titanium electrode	
	Sound power level	dB(A) 45	45
	Dimensions (D x H)	mm ø520x1160	ø520x1368
Controls	Net weight	kg 48	48
	On-board machine control WiFi module	Included Integrated	

1. Conditions: intake air 20° C DB (15° C WB), water inlet 15° C / outlet 55° C. 2. Test according to EN16147; air 7° C, water inlet 10° C.

3. Directive 2009/125/EC - ERP EU No. 814/2013 (SGS-CSTC certification for all models). 4. Refrigerant leakage contributes to climate change. When released into the atmosphere, refrigerants with a lower global warming potential (GWP) contribute less to global warming than those with a higher GWP. This appliance contains a refrigerant with a GWP of 0.02. If 1 kg of this refrigerant fluid were released into the atmosphere, therefore, the impact on global warming would be 50 times less than 1 kg of CO₂, over a period of 100 years. Under no circumstances should the user try to intervene on the refrigerant circuit or disassemble the product. Always contact qualified personnel if necessary.

HEATING

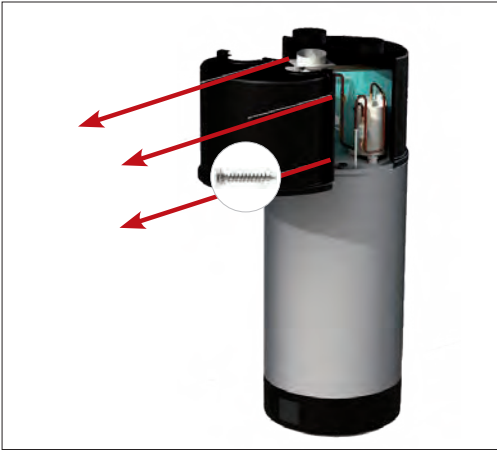

HORIZONTALLY REMOVABLE UPPER HEAT PUMP BODY

Easier maintenance and less space required for installation.

COMFORT AT HOME

Designed to be installed in the kitchen, like a traditional boiler, the “Ducted Kitchen” series fits comfortably inside the kitchen column, with air expelled outside.

INSTALLATION WARNINGS

1. It is mandatory to install a safety and non-return valve on the cold water inlet. Failure to do so may seriously damage the equipment. Use a valve with a 0.7 MPa setting. For the installation location, refer to the piping connection diagram.
2. The safety valve discharge pipe must be vertical and must not be placed in an environment at risk of freezing.
3. Water must be able to drip freely from the tube and its end must be left free.
4. The safety valve must be tested regularly to ensure it is working properly and to remove any limescale that may be blocking it.
5. Installation must be carried out in strict compliance with current regulations (R290).



SAFETY

The titanium anode provides corrosion protection without the need for regular replacement like magnesium anode.

Anti-legionella system: the danger of legionella bacteria is averted thanks to periodic cycles that raise the temperature of the water inside the tank above 70° C.

HYDRAULIC CONNECTION DIAGRAM

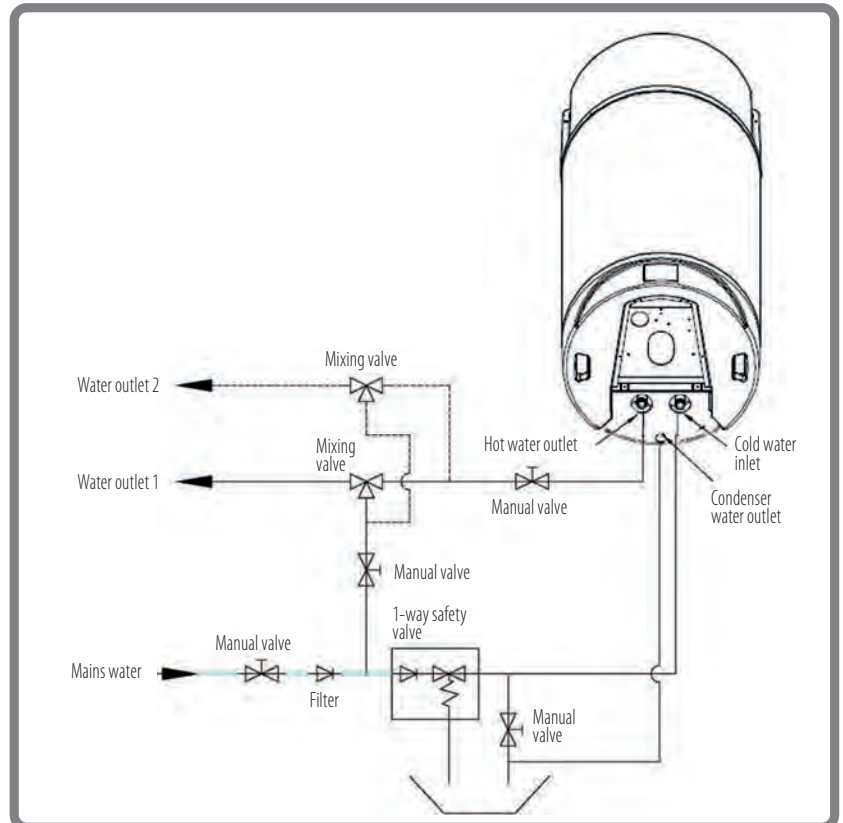

HEATING

HOT WATER

HWMB 2211 A | HWMB 2311 A | HWMB 2411 A

Monobloc heat pump water heater
200/300/400 litres “Ducted” series



Monobloc floor-standing heat pump water heater

R134A | Refrigerant gas

InoxStainless steel tank

60° C | Hot water with compressor only

Improved **Titanium Anode** electronic management

Anti-legionella cycle | Customizable for different needs or excludable

Innovative soft touch control panel for easy commissioning, use and maintenance

ErP Ready

No solar thermal integration



PERFORMANCE

MODEL	RATED LOAD	ENERGY CLASS	COP According EN 16147
HWMB 2211 A	200 L	A	2.64
HWMB 2311 A	300 L	A	2.69
HWMB 2411 A	400 L	A	2.81

Model		HWMB 2211 A	HWMB 2311 A	HWMB 2411 A
Tank volume	L	200	300	400
Solar integration coil (Stainless Steel)	m ²	not present	not present	not present
Nominal thermal power ¹	W	2020	2020	2020
Nominal power consumption ¹	W	486	486	486
Nominal COP ¹	W/W	4.16	4.16	4.16
Nominal DHW production capacity ¹	L/h	43.2	43.2	45
COPDHW ²	W/W	2.64	2.69	2.81
Test cycle profile ²	-	L	XL	XL
Hot water volume at 40°C ²	L	251	380	439
Energy efficiency (η wh) ³	%	110	111	114
Energy efficiency class ³	-	A	A	A
IP protection rating	-	IPX1	IPX1	IPX1
Hot water temperature regulation range	°C	10~70 (50 default)	10~70 (50 default)	10~70 (50 default)
Maximum hot water temperature compressor only	°C	60	60	60
Electrical data	Power supply	Ph-V-Hz 1-220~240V-50Hz		
	Integrative electrical resistance	1500		
	Maximum current (including resistance)	10.00		
Refrigerant circuit data	Refrigerant ⁴	R134a (1430)		
	Quantity	0.80		
	Tons of CO2 equivalent	1.144		
	Compressor	Rotary ON/OFF		
Hydraulic data	Tank material	Stainless Steel 304		
	DHW connections	G1" (DN25)		
	Solar coil connections	-		
	Maximum operating pressure	10		
Air ducts	Air flow rate (with ducts)	400		
	Fan's static pressure	60		
	Internal diameter	180		
	Maximum length	6		
Product specifications	Work field	-5~+43		
	Anode type	Titanium electrode with alarm LED		
	Sound power level	55		
	Dimensions (Diam. x H)	ø560x1745		
	Net weight	90		
Controls	On-board machine control	Incluso		
	WiFi module	Integrated		

1. Conditions: intake air 20°C DB (15°C WB), water inlet 15°C / outlet 55°C. 2. Test according to EN16147; air 7°C, water inlet 10°C.

3. Directive 2009/125/EC - ERP EU n. 814/2013 (TUV Sud certification for all models). 4. Refrigerant leakage contributes to climate change. If released into the atmosphere, refrigerants with a lower global warming potential (GWP) contribute less to global warming than those with a higher GWP. This appliance contains a refrigerant with a GWP of 1430. Therefore, if 1 kg of this refrigerant were released into the atmosphere, the impact on global warming would be 1430 times higher than 1 kg of CO₂, over a period of 100 years. Under no circumstances should the user attempt to intervene on the refrigerant circuit or disassemble the product. If necessary, always contact qualified personnel.

HEATING

COMFORT AT HOME

Programming to take advantage of any advantageous time slots on the electricity rate and have hot water available when needed.

Two operating modes: maximum savings with the use of the compressor alone or maximum speed with the simultaneous use of the heat pump and integrated electric resistance, to produce large quantities of DHW in short times.

INSTALLATION WARNINGS

1. It is mandatory to install a safety and non-return valve on the cold water inlet. Failure to do so may seriously damage the equipment. Use a valve with a 0.7 MPa setting. For the installation location, refer to the piping connection diagram.
2. The safety valve discharge pipe must be vertical and must not be placed in an environment at risk of freezing.
3. Water must be able to drip freely from the tube and its end must be left free.
4. The safety valve must be tested regularly to verify its functioning and to remove any limescale that may block it.

SAFETY

Since the heat exchanger is outside the tank, no contamination between water and refrigerant is possible.

Anti-legionella system: the danger of legionella bacteria is averted thanks to periodic cycles that raise the temperature of the water inside the tank above 65° C.

The titanium anode protects the tank from the corrosive action of water in an inexhaustible way: it guarantees greater reliability and lower maintenance costs compared to a solution with a magnesium anode.

HYDRAULIC CONNECTION DIAGRAM

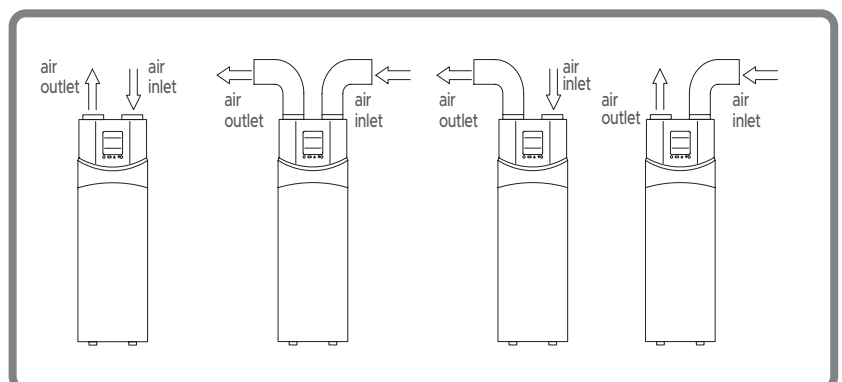
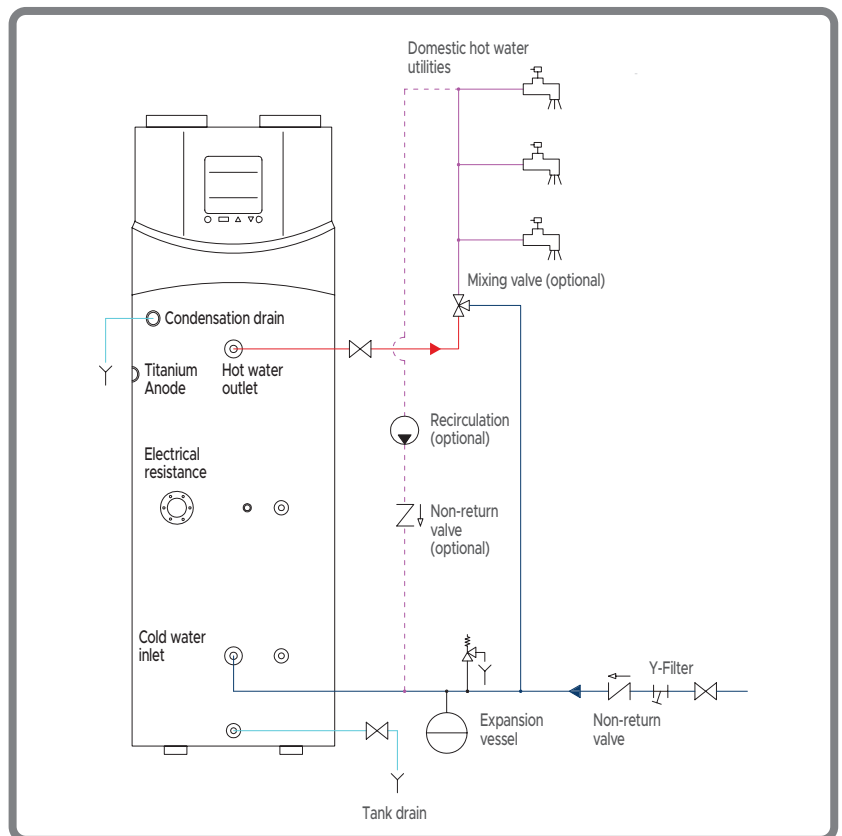

HEATING

HOT WATER

HWMB5 2211 HEA | HWMB5 2311 HEA
HWMB5 2411 HEA | HWMB5 4411 HEA

Monobloc heat pump water heater
200/300/400 litres "Ducted" series



Floor standing water heater with the possibility of integration with solar thermal energy
R134A | Refrigerant gas
Stainless steel tank

60° C | Hot water with compressor only
Improved **Titanium Anode** electronic management
Anti-legionella cycle | Customizable for different needs or excludable

Possibility of solar thermal integration

Innovative soft touch control panel for easy commissioning, use and maintenance
ErP Ready



PERFORMANCE

MODEL	RATED LOAD	ENERGY CLASS	COP According EN 16147
HWMB5 2211 HEA	200 L	A	2.61
HWMB5 2311 HEA	300 L	A	2.68
HWMB5 2411 HEA	400 L	A	2.61
HWMB5 4411 HEA	400 L	A	2.62

Model		HWMB5 2211 HEA	HWMB5 2311 HEA	HWMB5 2411 HEA	HWMB5 4411 HEA	
Tank volume	L	200	300	400	400	
Solar integration coil (Stainless Steel)	m ²	1.00	1.00	1.00	1.00	
Nominal thermal power ¹	W	2040	2040	2060	3285	
Nominal power consumption ¹	W	465	460	477	895	
Nominal COP ¹	W/W	4.39	4.43	4.32	3.67	
Nominal DHW production capacity ¹	L/h	43.50	43.50	45.00	70.50	
COPDHW ²	W/W	2.61	2.68	2.61	2.62	
Test cycle profile ²	-	L	XL	XL	XL	
Hot water volume at 40° ²	L	250	390	434	434	
Energy efficiency (η _{wh}) ³	%	106	110	108	108	
Energy efficiency class ³	-	A	A	A	A	
IP protection rating	-	IPX1	IPX1	IPX1	IPX1	
Hot water temperature regulation range	°C	10~70 (50 default)	10~70 (50 default)	10~70 (50 default)	10~70 (50 default)	
Maximum hot water temperature compressor only	°C	60	60	60	60	
Electrical data	Power supply	Ph-V-Hz 1-220~240V-50Hz				
	Integrative electrical resistance	W 1500				
	Maximum current (including resistance)	A	10.00	10.00	10.00	13.00
Refrigerant circuit data	Refrigerant ⁴	Type (GWP)	R134a (1430)	R134a (1430)	R134a (1430)	R134a (1430)
	Quantity	kg	1.0	1.0	1.0	0.9
	Tons of CO ₂ equivalent	t	1.430	1.430	1.430	1.287
	Compressor	type	Rotary ON/OFF			
Hydraulic data	Tank material	Stainless Steel 304				
	DHW connections	inches	G1" (DN25)	G1" (DN25)	G1" (DN25)	G1" (DN25)
	Solar coil connections	inches	G3/4" (DN20)	G3/4" (DN20)	G3/4" (DN20)	G3/4" (DN20)
	Maximum operating pressure	bar	10	10	10	10
Air ducts	Air flow rate (with ducts)	m ³ /h	400	400	450	800
	Fan's static pressure	Pa	60	60	60	60
	Internal diameter	mm	180	180	180	180
	Maximum length	m	6	6	6	6
Product specifications	Work field	°C -5~+43				
	Anode type	Titanium electrode with alarm LED				
	Sound power level	dB(A)	58.2	58.2	58.0	59.2
	Dimensions (Diam. x H)	mm	Ø560x1745	Ø640x1840	Ø700x1880	Ø700x1880
	Net weight	kg	95	105	115	118
Controls	On-board machine control	Included				
	WiFi module	Integrated				

1. Conditions: intake air 20°C DB (15°C WB), water inlet 15°C / outlet 55°C. 2. Test according to EN16147; air 7°C, water inlet 10°C.

3. Directive 2009/125/EC - ERP EU n. 814/2013 (TUV Sud certification for all models). 4. Refrigerant leakage contributes to climate change. If released into the atmosphere, refrigerants with a lower global warming potential (GWP) contribute less to global warming than those with a higher GWP. This appliance contains a refrigerant with a GWP of 1430. Therefore, if 1 kg of this refrigerant were released into the atmosphere, the impact on global warming would be 1430 times higher than 1 kg of CO₂, over a period of 100 years. Under no circumstances should the user attempt to intervene on the refrigerant circuit or disassemble the product. If necessary, always contact qualified personnel.

HEATING

COMFORT AT HOME

Programming to take advantage of any advantageous time slots on the electricity rate and have hot water available when needed.

Two operating modes: maximum savings with the use of the compressor alone or maximum speed with the simultaneous use of the heat pump and integrated electric resistance, to produce large quantities of DHW in short times.

INSTALLATION WARNINGS

1. It is mandatory to install a safety and non-return valve on the cold water inlet. Failure to do so may seriously damage the equipment. Use a valve with a 0.7 MPa setting. For the installation location, refer to the piping connection diagram.
2. The safety valve discharge pipe must be vertical and must not be placed in an environment at risk of freezing.
3. Water must be able to drip freely from the tube and its end must be left free.
4. The safety valve must be tested regularly to verify its functioning and to remove any limescale that may block it.

SAFETY

Since the heat exchanger is outside the tank, no contamination between water and refrigerant is possible.

Anti-legionella system: the danger of legionella bacteria is averted thanks to periodic cycles that raise the temperature of the water inside the tank above 65° C.

The titanium anode protects the tank from the corrosive action of water in an inexhaustible way: it guarantees greater reliability and lower maintenance costs compared to a solution with a magnesium anode.

HYDRAULIC CONNECTION DIAGRAM

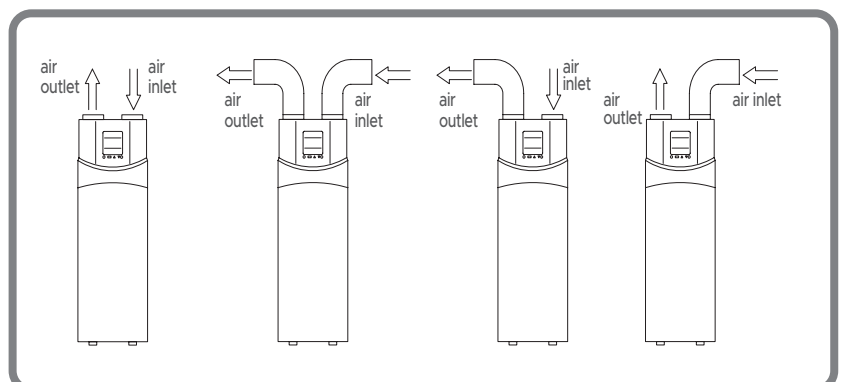
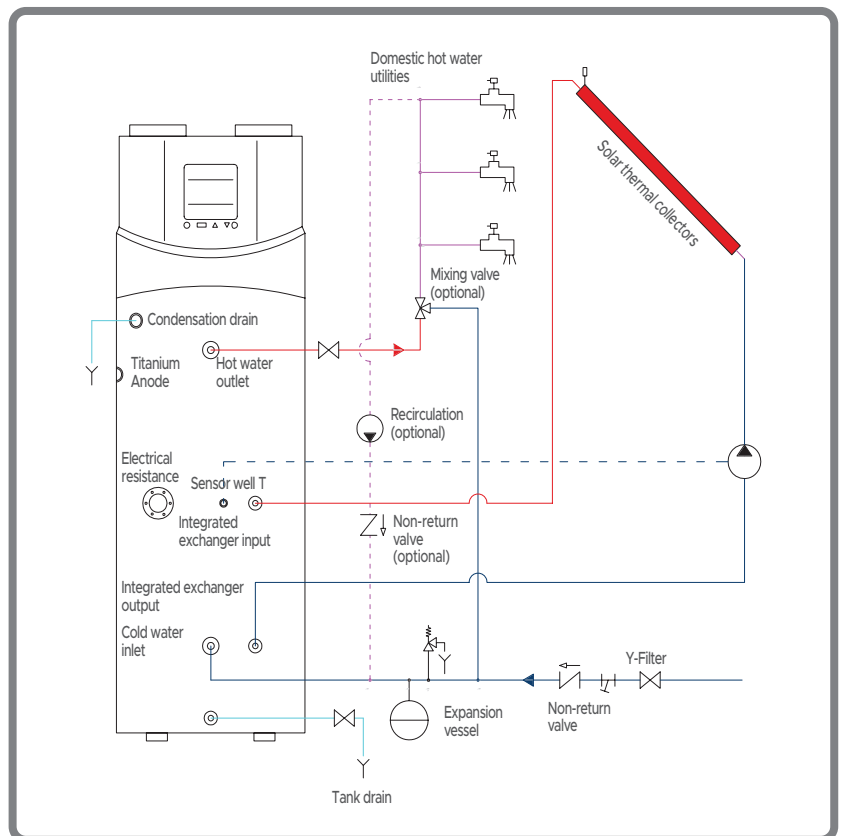

CONTROLS





CONTROLS

- 70** R32 Individual Standard Controls
- 71** Appendix
- 72** Individual controls for I.U. XRV-P
- 72** Group controls for I.U. XRV-P

R32 INDIVIDUAL STANDARD CONTROLS



**R32
LUMINA**

- On/off.
- Modes: cooling, heating, dehumidification, automatic, ventilation.
- I-Feel: temperature sensor on the remote control.
- Timer on/off.
- Adjustable fan speed: low-medium-high-turbo-automatic.
- Vertical swinging of the air outlet flaps.
- ECO mode.
- Sleep.
- Silence.
- Display: Turn the bright display on/off.
- Light: enable/disable display based on ambient brightness.
- iClean: self-cleaning of dust on the heat exchanger, drying of condensation.
- Child Lock.
- 8°C heating.



**R32
AIKO**

- On/off.
- Modes: cooling, heating, dehumidification, automatic, ventilation.
- SOFT: in cooling mode, the micro-perforated flap closes, avoiding a direct jet of cold air on people.
- I-Feel: temperature sensor on the remote control.
- Timer on/off.
- Adjustable fan speed: silent-low-medium low-medium-medium high-high-turbo-automatic.
- Vertical swinging of the air outlet flaps.
- ECO mode.
- Sleep.
- Silence.
- Display: Turn the bright display on/off.
- iClean: self-cleaning of dust on the heat exchanger, drying of condensation.
- Child Lock.
- 8°C heating.



**R32
AIKO-S**

- 4D Air Flow
- Health (UVC): air purification through ultraviolet radiation.
- On/off.
- Modes: cooling, heating, dehumidification, automatic, ventilation.
- SOFT: in cooling mode, the micro-perforated flap closes, avoiding a direct jet of cold air on people.
- I-Feel: temperature sensor on the remote control.
- Timer on/off.
- Adjustable fan speed: silent-low-medium low-medium-medium high-high-turbo-automatic.
- Vertical and horizontal swinging of the air outlet flaps.
- ECO mode.
- Sleep.
- Silence.
- Display: Turn the bright display on/off.
- iClean: self-cleaning of dust on the heat exchanger, drying of condensation.
- Child Lock.
- 8°C heating.



**R32
Compact Cassette,
Slim Cassette, Console,
Floor/Ceiling**

- On/Off.
- Modes: cooling, heating, dehumidification, ventilation, automatic.
- Fan speed: low, medium, high, automatic.
- Swing: Adjusts the position of the air outlet flaps.
- Turbo.
- Silence.
- Timer on/off.
- Sleep.
- I-Feel.
- I-Clean.

R32 INDIVIDUAL STANDARD CONTROLS



R32 WCD-05

Standard for ducted medium static pressure.

Optional for:
Compact Cassette, Slim Cassette, Console, Floor/Ceiling.

- On/Off.
- Modes: cooling, heating, dehumidification, ventilation, automatic.
- Fan speed: low-medium-high.
- Timer on/off.
- Turbo.
- Sleep.
- Silence.
- ECO.
- Child Lock



R32 wall type LUMINA MULTI

- On/off.
- Modes: cooling, heating, dehumidification, automatic, ventilation.
- I-Feel: temperature sensor on the remote control.
- Timer on/off.
- Adjustable fan speed: low-medium-high-turbo-automatic.
- Vertical swinging of the air outlet flaps.
- ECO mode.
- Sleep.
- Silence.
- Display: Turn the bright display on/off.
- Light: Turns display on/off based on ambient brightness.
- iClean: self-cleaning of dust on the heat exchanger, drying of condensation.
- Child Lock.
- 8°C heating.

APPENDIX

Control Functions Detail

Sleep: the unit regulates the room temperature to achieve maximum comfort along with energy saving. The unit automatically exits this mode in case of 10 hours of continuous operation.

Turbo: the unit operates at maximum speed to quickly reach the desired cooling or heating temperature.

Display: turn on/off the unit's display.

Silence mode: attenuation of the compressor frequency with consequent reduction of noise emissions.

Heating Function 8°C: prevents the room temperature from falling below 8° C.

I-Feel Function: adjusts the room temperature according to that detected by the remote control to obtain maximum comfort.

Eco Function: the system will modulate the operating frequency, creating the right compromise between performance and energy saving.

iClean: self-cleaning of dust on the heat exchanger and drying of condensation to prevent the formation of mold and bacteria.

Swing: positioning of motorized flaps.

Soft Function: in cooling mode, the micro-perforated flap closes, avoiding a direct jet of cold air on people.

Health Function (UVC): purification of supply air by germicidal ultraviolet radiation.

Light: automatically activate/deactivate display based on ambient brightness.

4D Air Flow: the flaps move automatically in all directions, distributing the supplied air evenly and ensuring maximum comfort.

Timer on/off: on or off timer, settable with a time range from 0.5 to 24 hours.

CONTROLS

INDIVIDUAL CONTROLS FOR I.U. XRV-P



DHIR-5-6-XRV-K-P

- On/off.
- Mode: cooling, heating, dehumidifying, ventilation, automatic.
- Horizontal louver swing (only active for floor/ceiling I.U.).
- Vertical louver swing.
- Reset.
- Key lock.
- Fan speed: low, medium, high or automatic.
- Clock & On/off timer.
- Eco function.



DHW-5-6-XRV-P

- On/off.
- Mode: cooling, heating, dehumidifying, ventilation, automatic.
- Vertical louver swing.
- Silent mode.
- Reset.
- Key lock.
- Fan speed: low, medium, high or automatic.
- Clock & On/off timer.
- Eco function.
- Filter cleaning indicator.

GROUP CONTROLS FOR I.U. XRV-P



DHWT-16-XRV-P

- On/off.
- Mode: cooling, heating, dehumidifying, ventilation, automatic.
- Vertical louver swing.
- Silent mode.
- Reset.
- Key lock.
- Fan speed: low, medium, high or automatic.
- Clock & On/off timer.
- Weekly Timer.
- Eco function.
- Reminder of filter cleaning.
- Group control up to 16 I.U.

HOKKAIDO

Due to the continuous technological evolution of the products, we reserve the right to change the technical specifications at any time and without prior notice. The products depicted are only examples of the application types.

hokkaido.it



TERMAL SALES S.r.l.

Via della Salute 14 Tel. +39 051 4133 111
40132 Bologna Italy **www.termal.it**